

ED 022 491

LIBRARY PLANNING STUDY. REPORT TO THE BUREAU OF LIBRARY EXTENSION, DEPARTMENT OF EDUCATION,
COMMONWEALTH OF MASSACHUSETTS.

Little (Arthur D.), Inc., Boston, Mass.

Report No-C-69270

Pub Date Aug 67

Note-83p.

EDRS Price MF-\$0.50 HC-\$3.40

Descriptors-CENTRALIZATION, HANDICAPPED, INSTITUTIONS, *INTERLIBRARY LOANS, LIBRARIES, *LIBRARY
COOPERATION, *LIBRARY NETWORKS, LIBRARY PROGRAMS, *LIBRARY SERVICES, LIBRARY TECHNICAL
PROCESSES, STATE AGENCIES

Identifiers-*Massachusetts

This evaluation was conducted to review library service to Massachusetts state institutions and to examine levels of present or potential cooperation among all types of libraries. Based on interviews and questionnaires, the study is divided into three areas: resources for all types of libraries, service to state institutions, and library service for the physically handicapped. It is concluded that Massachusetts library resources are generally underused and often inefficiently maintained. Recommendations include: (1) a total library network, involving a State Library Center with responsibility for centralized ordering, cataloging, and processing and a union catalog to serve all libraries, (2) increased public library cooperation and retention of the present regional system headquarters libraries, (3) participation by college, university, and special libraries in State Library Service Center activities, (4) expansion of the Bureau of Library Extension functions for school libraries, and establishment of 5 regional centers for nonbook school library materials, (5) participation by special libraries in the State Library Service Center's interlibrary loan program, (6) establishment or improvement of institutional libraries, and (7) improvement of service to the handicapped. A 4 year program to implement these recommendations is outlined.
(JB)

LZ 000552

Library Planning Study: Massachusetts

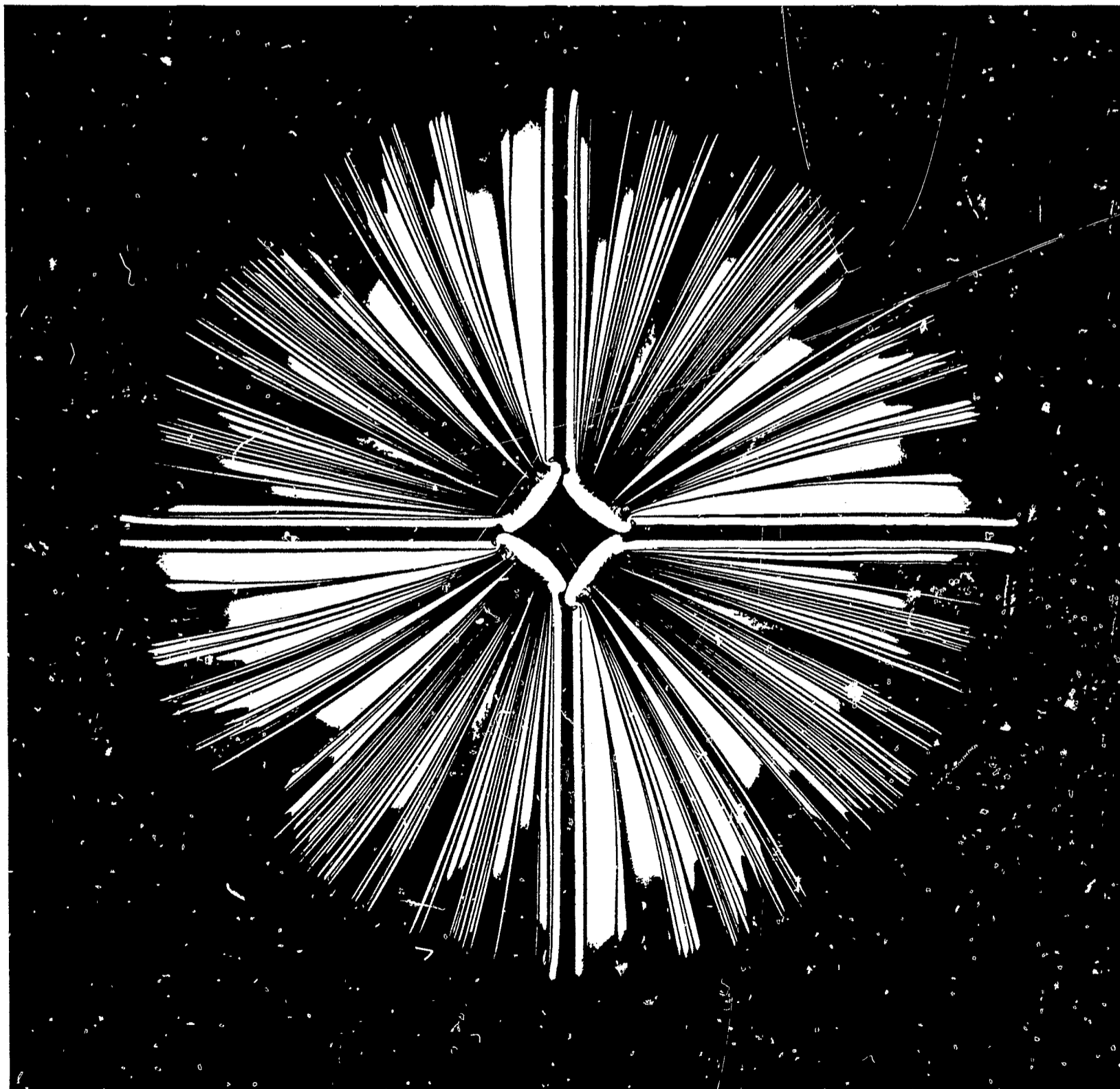

LZ000552

Arthur D. Little, Inc.

U.S. DEPARTMENT OF HEALTH, EDUCATION & WELFARE
OFFICE OF EDUCATION

THIS DOCUMENT HAS BEEN REPRODUCED EXACTLY AS RECEIVED FROM THE
PERSON OR ORGANIZATION ORIGINATING IT. POINTS OF VIEW OR OPINIONS
STATED DO NOT NECESSARILY REPRESENT OFFICIAL OFFICE OF EDUCATION
POSITION OR POLICY.

LIBRARY PLANNING STUDY

"PERMISSION TO REPRODUCE THIS
~~COPYRIGHTED~~ MATERIAL HAS BEEN GRANTED

BY Arthur D. Little

TO ERIC AND ORGANIZATIONS OPERATING
UNDER AGREEMENTS WITH THE U.S. OFFICE OF
EDUCATION. FURTHER REPRODUCTION OUTSIDE
THE ERIC SYSTEM REQUIRES PERMISSION OF
THE COPYRIGHT OWNER."

Report to

THE BUREAU OF LIBRARY EXTENSION,
DEPARTMENT OF EDUCATION,
COMMONWEALTH OF MASSACHUSETTS

August 1967

C-69270

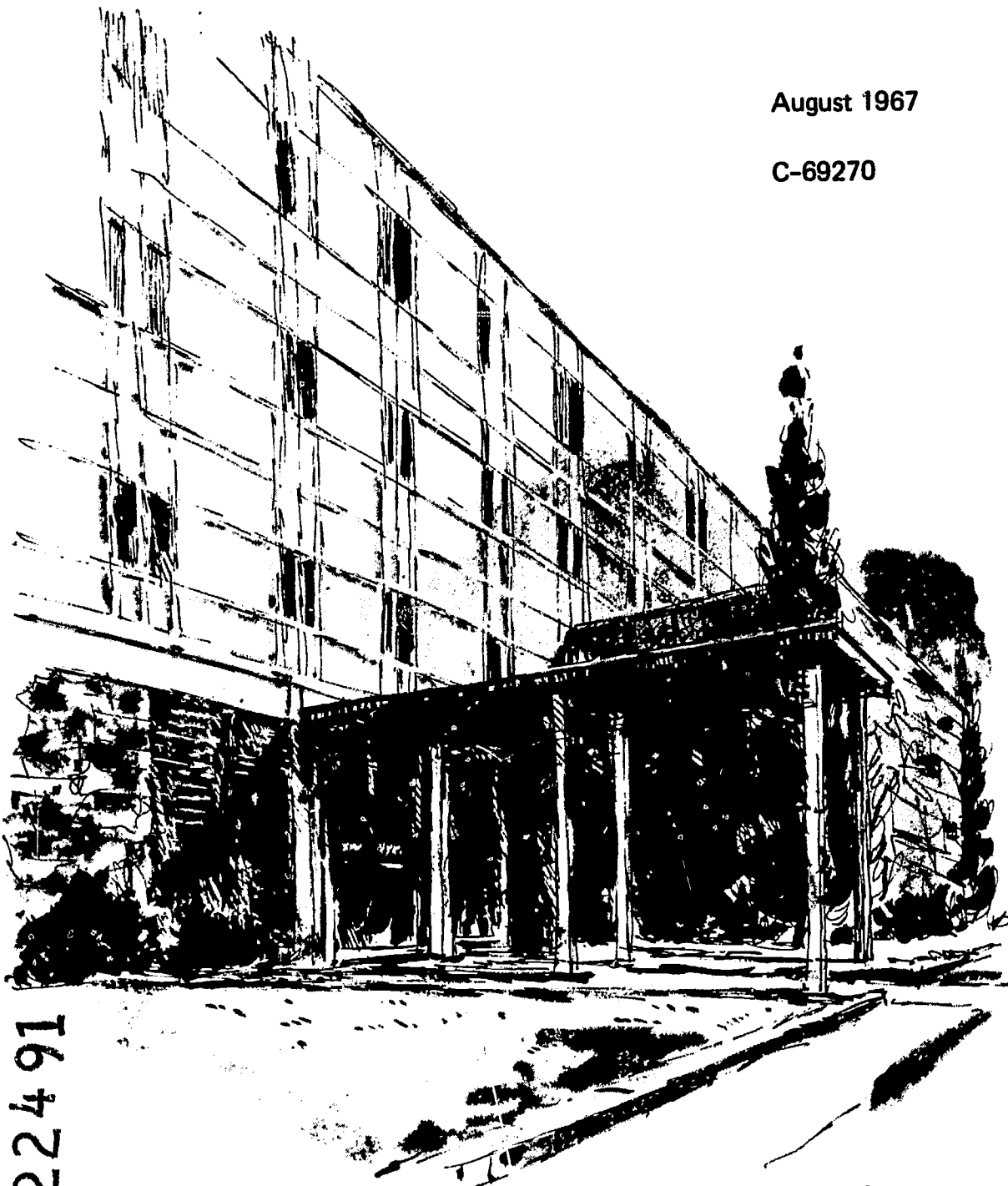

Arthur D. Little, Inc.

ED022491

This report is rendered upon the condition that it is not to be reproduced in whole or in part for advertising or other purposes without the special permission in writing of Arthur D. Little, Inc.

ACKNOWLEDGMENTS

The case team is grateful to Mrs. V. Genevieve Galick, Director, Bureau of Library Extension, Department of Education, Commonwealth of Massachusetts, and to Miss Mary Burgarella, Senior Supervisor for Library Development, of that bureau, for their guidance.

We also are thankful to the Advisory Council on the Library Services and Construction Act for its constructive bringing together of many points of view about the three planning areas. Members of the council and their institutional affiliations are:

Public Libraries:

Philip McNiff, Director, Boston Public Library
Jack Bryant, Director, Worcester Public Library
Frank Keough, Director, Springfield City Library

School Libraries:

Mrs. Mildred Wagner, Needham Schools Coordinator
Miss Jane Hannigan, Simmons College, School of Library Science

Academic Libraries:

Dr. Francis Guindon, Assistant Director, Massachusetts Division
of State Colleges
Tilton Barron, Librarian, Clark University
Reverend Brendan Connolly, Director of Libraries, Boston College
Libraries
Douglas Bryant, University Librarian, Harvard University Library

Special Libraries:

I. Albert Matkov, State Librarian, Massachusetts State Library
Samuel Sass, Librarian, General Electric, Pittsfield Plant
Ann T. Curran, Librarian, Inforonics, Inc., Cambridge
Stephen Riley, Director, Massachusetts Historical Society Library
Marcus McCorison, Librarian, American Antiquarian Society

Institutions:

Mr. Francis Maloney, Deputy Director of Institutions, Division
of Youth Service
Mr. Pasquale Principe, Assistant Superintendent, Division of Youth
Service Institute for Juvenile Guidance
Mrs. Marie Gately, Director, Department of Public Health, Division
of Health Education

Dr. Margaret Brayton, Massachusetts Hospital School
Dr. Louis Orzack, Assistant Director, Department of
Mental Health, Division of Mental Retardation
Mrs. Ruth Spencer, School Librarian, Fernald School
Gerald O'Loughlin, Department of Correction, Super-
intendent of Education
Carlo Geronimi, Institute Representative, Department
of Correction

Organizations for the Handicapped:

Richard T. Goldberg, Massachusetts Rehabilitation
Commission
John Mungovan, Director, Massachusetts Commission
for the Blind
Edward Waterhouse, Director, Perkins School for the
Blind

The following Arthur D. Little, Inc., personnel participated in a major way in this
study:

Walter W. Curley, Case Leader
Dr. Anton S. Morton, Day-to-day charge
Mary Beth Braden
Talbot Bulkley
Patricia K. Finnegan
Carolyn Heller
Arleen Leibowitz
Dr. I. W. Miller, Jr.
Janet Price

TABLE OF CONTENTS

	Page
List of Tables	vii
List of Figures	ix
I. SUMMARY	1
A. PURPOSE AND SCOPE	1
B. CONCLUSIONS	1
C. RECOMMENDATIONS	2
D. PROGRAM SCHEDULE	6
II. INTERLIBRARY COOPERATION	7
A. RECONNAISSANCE INTERVIEWS	7
B. QUESTIONNAIRE AND INTERVIEW PROGRAM	8
C. PRESENT STATUS AND RECOMMENDATIONS BY TYPE OF LIBRARY	23
D. RECOMMENDED STATE SYSTEM	31
III. LIBRARY SERVICES TO INSTITUTIONS	40
A. THE PRESENT SITUATION	40
B. FUTURE LIBRARY SERVICES TO INSTITUTIONS	51
IV. LIBRARY SERVICES FOR THE HANDICAPPED	57
A. PRESENT SITUATION	57
B. FUTURE LIBRARY SERVICES TO THE HANDICAPPED	68

TABLE OF CONTENTS (Continued)

	Page
V. NEW ENGLAND LIBRARY COOPERATION	72
A. NEED	72
B. PRELIMINARY REGIONAL CENTER	73
C. EXPANDED REGIONAL CENTER	73
D. ORGANIZATION AND FUNDING	74

LIST OF TABLES

Table No.		Page
1	Participants in Questionnaire and Interview Program	8
2	Library Use Statistics	10
3	Interlibrary Loans (ILL's)-- Eastern Region	11
4	Interlibrary Loans (ILL's)--Central Region	12
5	Interlibrary Loans (ILL's)--Western Region	13
6	Communications Methods, Reciprocal Arrangements, and Classification Schemes	14
7	Cooperative Programs	15
8	Independence-Cooperative Systems	16
9	Authorized Funding Under Title III--Library Cooperation	36
10	Authorized Funding Under Title IV-A--Library Service to Institutions	38
11	Authorized Funding Under Title IV-B--Library Service to the Handicapped	39
12	Characteristics of Surveyed Institutional Libraries	45
13	Estimated Inventory of Braille and Large-Print Volumes	58
14	Estimated Number of Handicapped in Massachusetts By Type	59
15	Blind Persons on the Massachusetts Register of the Blind By Age and Sex, December 31, 1964	60
16	Estimated Number of Persons Requiring Various Types of Special Library Facilities	63

LIST OF FIGURES

Figure No.		Page
1	Total Volumes Versus Interlibrary Loans Sent and Received	18
2	Organization Structure of State Library Network	32

I. SUMMARY

A. PURPOSE AND SCOPE

Under Titles III, IV-A, and IV-B of the U. S. Library Services and Construction Act of 1966, Massachusetts has been asked to further cooperation among libraries in the state and to review its library programs of service to institutions and to the handicapped. Arthur D. Little, Inc. (ADL), was asked to evaluate library services offered by institutions operated or substantially supported by the state, services performed by public and private agencies for the physically handicapped, and levels of operation which exist, or could exist, among libraries.

Our study was broken down into three segments, corresponding to the titles of the Library Services and Construction Act of 1966:

- **Title III.** Plan the policies and objectives for the systematic and effective coordination of the resources of school, public, academic, and special libraries and special information centers for improved services to clientele.
- **Title IV-A.** Plan the policies and objectives for the establishment or improvement of library services in residential training schools, reformatories, penal institutions, orphanages, or general or special institutions or hospitals operated or substantially supported by the state.
- **Title IV-B.** Plan the policies and objectives for the establishment or improvement of state plans for library services to physically handicapped persons, including the blind and the visually handicapped, certified as unable to read or to use conventional printed materials as a result of physical limitations.

B. CONCLUSIONS

As a result of our study, we conclude that the library resources in Massachusetts are generally underused and often inefficiently maintained. Primary reasons for this condition are:

- Insufficient funding;
Lack of strong organizational structure;
- Lack of central "finding tools";
- Slow communications;
- Undue delays in interlibrary loans;
- Lack of effective structuring at the system and state library levels;
- Dependence on large resource centers;

- Time-consuming business functions such as ordering, cataloging, processing;
- Differences in local legal situations;
- Local independence and/or jealousy;
- Lack of school library organization on the state level;
- Minimal patron knowledge of available state-wide services; and
Lack of long-range planning.

C. RECOMMENDATIONS

1. Total Library Network

- (a) Substantially increase state aid for library service.
- (b) Revise salary schedule for the staff of the Bureau of Library Extension; present salaries are inadequate.
- (c) Create a State Library Service Center, responsible for centralized ordering, cataloging, and processing and the maintenance of a union catalog and union list of serials, which would serve all libraries in the state.
- (d) At the state center, use electronic data processing equipment, including a computerized union catalog, for information retrieval.
- (e) Create new regional headquarters to handle regional cataloging and processing. (The state center should handle all ordering.) These headquarters would be under the direct supervision of the Bureau of Library Extension and coordinated with the State Library Service Center.
- (f) Send monthly printouts of the appropriate sections of the union catalog to the new regional headquarters during the initial stages of the program. As the union catalog becomes larger, install computer consoles in each region if needed to facilitate access to the main catalog.
- (g) To improve communication and delivery systems, provide:
 - (1) Truck delivery systems within the regions,
 - (2) Credit card telephone numbers for each regional headquarters, and
 - (3) Teletype installations at each regional headquarters and at the State Library Service Center.

2. Public Libraries

(a) Retain present regional system headquarters libraries to act as resource centers providing free access privileges to the libraries within their regions and offering area consultant services and related activities.

(b) Increase publicity efforts so that more readers will be aware of the available ILL services.

(c) Encourage public libraries to cooperate in building strength in selected subject areas.

(d) Establish reciprocal borrowing privileges among all the public libraries of the Commonwealth.

3. College and University Libraries

(a) Encourage colleges and universities, especially the smaller ones, to participate in the ordering, cataloging, and processing activities of the State Library Service Center.

(b) Encourage the smaller colleges, whose holdings are not listed in the National Union Catalog, to add to the union catalog for Massachusetts.

(c) Coordinate interlibrary loan activities of college and university libraries through the State Library Service Center to remove a burden from the resource libraries which will be reimbursed only for those interlibrary loan (ILL) transactions which go through the service center.

(d) Give college and university libraries which are considered resource libraries (because of extensive holdings of material not likely to be found elsewhere in the state) an annual grant from the Bureau of Library Extension, plus an additional sum for each search for ILL material, to offset the increasing burden being placed on the largest libraries. Only those requests which are not likely to be filled elsewhere and are likely to be in their collections will be channeled to the resource libraries.

4. School Libraries

(a) Expand the interlibrary loan program to include students at all levels.

(b) Do processing for school libraries through the State Library Service Center, in conjunction with the three regional headquarters for technical services. Handle only book material during the initial stages of the program; add nonbook material as the program matures.

(c) Establish regional centers, perhaps five, for the development and distribution of nonbook material, expensive but seldom-used book material, bibliographic tools, and back-up services.

(d) Develop a demonstration collection of appropriate school library materials at the Bureau of Library Extension.

(e) Provide an extensive collection of professional reading for school personnel at the Bureau of Library Extension, either expanding a present collection or creating a new one. Make all material available to teachers throughout the State on ILL, and encourage teachers to make regular use of the collection.

(f) Expand the Bureau of Library Extension's school library consultant program. Consultants should assist in book selection, direct seminars on school library service, and maintain the demonstration collection.

5. Special Libraries

(a) Encourage special libraries to participate in the ILL program of the State Library Service Center.

(b) Encourage special libraries to contribute to the Union Catalog listings of materials they hold, whether available for ILL or for photocopy use.

6. Institutional Libraries

(a) Associate professional librarians with the state department involved in servicing each type of institution.

(b) Recruit professional librarians for work in the individual institutions.

(c) Conduct in-service courses for library aides until enough trained librarians are available. Such courses would be conducted by the various departments dealing with the institutionalized when a professional librarian was available, by the Bureau of Library Extension otherwise.

(d) Provide libraries for the institutionalized at those institutions which do not have them.

(e) Improve present libraries, with emphasis on providing appropriate materials, including extensive audio-visual materials and equipment, for the types of persons served.

(f) Extend library hours to allow broader use of the facilities by the institutionalized.

(g) Make greater use of the state-wide interlibrary loan program in providing variety and depth, especially in those libraries which have very small collections.

(h) Provide more adequate collections for staff use.

(i) Provide consultants from the Bureau of Library Extension to:

- (1) Assist in the definition of goals,
- (2) Assist in the selection of materials,
- (3) Be responsible for interinstitutional library communication, and
- (4) Maintain a loan collection of special materials.

(j) Increase considerably the funds made available for library service to institutions.

7. Libraries for the Handicapped

(a) Through the Bureau of Library Extension, set up certification standards for handicapped persons to establish their eligibility to receive service. Include public librarians among the group of those eligible to grant such certification.

(b) Provide for "blanket" certification to hospitals, allowing them to serve temporarily handicapped patients, as well as terminal patients.

(c) Continue to use the Regional Library for the Blind to administer the greater part of the braille program.

(d) Provide all other special materials for the handicapped, on an ILL basis, through public library systems.

(e) Through the Bureau of Library Extension, maintain a union catalog of all special materials available in Massachusetts for the use of the handicapped. Provide copies of this catalog for local and institution librarians, and make audio-tape copies available to individual users.

(f) Issue numbered library cards to each person certified to use material for the handicapped to provide the Bureau of Library Extension with a means of coordinating circulation control.

(g) Provide consultants from the Bureau of Library Extension to:

- (1) Visit special materials distribution points to assist in the use of equipment, explain the program, and answer other related questions;
- (2) Instruct users individually in the use of the equipment and provide information on available services and the obtaining of these services.

D. PROGRAM SCHEDULE

1. Suggested Program

First Year

- Build staff at Bureau of Library Extension and newly created State Library Service Center.
- Build system design and program for computer operations at State Library Service Center.
- Create and staff five regional school resource centers.
- Begin service to institutions and the handicapped.

Second Year

- Build staff at three regional service centers.
- Begin work on union catalog and, before year's end, develop cataloging codes and processing procedures.
- Have service to institutions and to the handicapped fully operational.
- Have computer programs tested and fully operational.

Third Year

- Begin centralized processing on a limited basis.
- Have other aspects of state and regional service centers fully operational.
- Develop contracts with resource libraries.
- Begin building special resource collections.

Fourth Year

- Have all aspects of the enlarged program of library service fully operational.

2. Alternative Program

If funding for total program is not available immediately a limited program should be implemented. The program would include the following:

- (a) Consultant staff buildup, at the Bureau of Library Extension;
- (b) One school center as pilot project; and
- (c) Buildup of special resources at the state level to handle the needs of the institutionalized and the handicapped.

II. INTERLIBRARY COOPERATION

Several of the most extensive and specialized libraries in the country are located in Massachusetts. These include the complex of libraries at Harvard University – Widener Library's general collection, the Countway Medical Library, Baker Library of the Harvard Graduate School of Business Administration, Houghton Library's rare book collection, and others – the scientific and technological collections of MIT and the NASA Research Center, the large collections at other colleges, and the special libraries of many industrial firms. These extensive resources are underused, primarily because relationships between public libraries and between public libraries and academic, school, and special libraries are largely informal and/or loosely structured. Regional systems are in operation for public libraries, but the absence of a strong administrative organization hampers their effectiveness. Although the Bureau of Library Extension does offer advice and assistance to local libraries, it does not have the authority to maintain adequate standards of library service on the local level. Through a series of interviews and questionnaires, including a cross-section of libraries throughout the state, we have attempted to pinpoint the existing problems so that means for achieving greater use of all library resources by the residents of the state could be determined.

A. RECONNAISSANCE INTERVIEWS

To assess the library situation in Massachusetts, we studied present library activities, the cooperation between libraries, and librarians' estimates of their needs, resources, and aims. An effort was also made to include a variety of types of library. We conducted interviews with persons experienced in the areas under investigation and acquainted with people working in the relevant areas. The persons interviewed were:

- (1) Miss Alice Anderson, Librarian, Wayland Laboratories, Raytheon Corporation;
- (2) Mr. Jack Bryant, Director, Worcester Public Library;
- (3) Mr. David Clay, Director, University of Massachusetts Library;
- (4) Mr. Thomas Higgins, School Librarian, Weston Public Schools; and
- (5) Mr. Kenneth Shaffer, Director of School of Library Science, Simmons College.

During this phase of our work, we tried to define the areas which we would later study in depth. In our interviews, we sought answers to the following questions:

- (1) What are the issues to be resolved?
- (2) What are possible solutions?
- (3) What are present trends in library services in Massachusetts?
- (4) What imaginative and progressive interlibrary cooperative programs are now in operation in Massachusetts?
- (5) What special issues, problems, and challenges make Massachusetts different from other states?

At the conclusion of these reconnaissance interviews, we felt that the issues which should be emphasized in the study had been sufficiently defined. Accordingly, a questionnaire and interview guide were developed to permit a broader sampling of library activity in the State. We presented our approach to the eliciting of the necessary information to the advisory committee. After refining the questionnaire with the help of the advisory committee, we began the data-gathering phase of our work.

B. QUESTIONNAIRE AND INTERVIEW PROGRAM

1. Scope of the Survey

The *American Library Directory* lists 658 public, college, and special libraries in Massachusetts. In addition, there are about 2,000 public and private school libraries in the state. A systematic survey of all libraries in a state as large as Massachusetts would be difficult, if not impossible. Experience indicates that only about 25% returns can be expected from a general mail survey. Because of time and expense limitations, we selected a cross-section of the total number of libraries in the state for the purposes of information gathering. If the questionnaire were followed up with personal interviews, we believed that optimal results could be achieved, particularly since more substantive questions could be asked during an interview than could be placed in the questionnaire.

Participants in the questionnaire and subsequent interview program were chosen on the basis of geographic location, as well as size and type of library which they represented. The individuals and the libraries they represented are listed in Table 1.

TABLE 1 PARTICIPANTS IN QUESTIONNAIRE AND INTERVIEW PROGRAM

PERSON	TITLE	INSTITUTION	LOCATION
Rowell L. Waller	Librarian	Attleboro Public Library	Attleboro
Phillip J. McNiff	Director	Boston Public Library	Boston
Ida L. Anderson	Librarian	Cotuit Public Library	Cotuit
Arthur J. Kissner	Librarian	Fitchburg Public Library	Fitchburg
Lawrence E. Wikander	Librarian	Forbes Library	Northampton
Franklin P. Taplin	Librarian	Western Mass. Regional Library	Springfield
Joseph S. Hopkins	Librarian	Watertown Free Public Library	Watertown
Jack W. Bryant	Director	Worcester Public Library	Worcester
Kesley B. Sweatt	Librarian	Massachusetts Film Cooperative	Boston
Newton F. McKeon	Librarian	Amherst College	Amherst
Brendan C. Connolly, S.J.	Librarian	Boston College Libraries	Newton
Gustave A. Harrer	Director	Boston University Libraries	Boston
Jackson Lethbridge	Librarian	Hampshire Interlibrary Center	Amherst
Frances Atwood	Librarian	Lasell Junior College	Auburndale
Margaret L. Johnson	Librarian	Smith College Library	Northampton
Neil B. Olson	Librarian	State College at Salem Library	Salem
David Clay	Acting Director	University of Massachusetts Library	Amherst
James Tanis	Librarian	Yale University	New Haven (Conn.)
Sara Jaffarian	Librarian	Lexington Schools	Lexington
Mildred E. Wagner	Librarian	Needham High School	Needham
Barbara McDonnell	Librarian	Phillips Academy	Andover
Samuel Sass	Librarian	General Electric Company	Pittsfield
A. A. Del Frate	Librarian	NASA Research Center	Cambridge

2. Results

Tables 2 through 8 give the statistical results of the questionnaire and interviews. It is unusual to mix types of libraries in a statistical analysis, but we felt that it was valid for the purposes of this study. Table 2 summarizes the basic budget and use figures given by the libraries interviewed, presenting ratios between size of collection, number of persons using the library, circulation, and budget. The table indicates that in some categories the libraries vary substantially. For example, comparing the ratio of budget to population served, we find a low of 20¢/capita at the Western Massachusetts Regional Library System Headquarters (WMRLS) and a high of \$137/capita at Smith College. On the other hand, the ratio of interlibrary loan to total circulation is fairly standard for all libraries interviewed. Smith College again showed a high of 2%; three libraries registered 1%, and nine libraries less than 1%. In categories showing a wide variation, the colleges and universities were generally at the top of the scale, the regional centers at the lower end. This ranking is understandable in view of the different functions of the libraries.

Tables 3, 4 and 5 divide the libraries interviewed into the three regions comprising the state library network. These tables present information on interlibrary loans (ILL): the number of requests made and received, the number of books or copies actually borrowed or loaned, and the types of libraries involved in the ILL process. The tables indicate that colleges, regional headquarters, and large public libraries account for most of the ILL activity in the state, the smaller public libraries using the service to lesser degrees. Research activities on the college level account for this library group's extensive use of ILL, but one would expect that public libraries with small collections would make greater use of ILL than the large systems. Apparently, the public is making more and more demands on larger libraries, assuming that they will have the material because of their size. Very little interloan activity seems to occur at the school library level, primarily because students are not encouraged to use ILL. In some cases, public libraries tend to serve this function, since they, theoretically, can make the resources of the total library network available to the students; but, in other cases, public libraries will not use ILL for students. There appears to be little ILL activity among special libraries; however, their representation in the sample was quite limited. Evidently the special libraries participate in ILL either among themselves or through large resource libraries (e.g., Harvard, MIT). Public and college libraries display a certain amount of interaction, colleges tending to lend more books to public libraries than they borrow. Colleges generally borrow needed books from other colleges.

Table 6 gives the communications methods, reciprocal arrangements, and classification schemes used by several of the libraries. Only four of the libraries interviewed expressed dissatisfaction with the present ILL system, and only five do not use the standard ALA form. When seeking material on interloan, the mail requests are a little more frequent than telephone requests. The large libraries also make use of teletype and special messengers when necessary. The majority of libraries interviewed have some kind of reciprocal arrangement with other libraries. Eight have card privileges for persons outside their immediate service area, and only three charge nonmember fees. Most of the colleges use the Library of Congress classification scheme; the public libraries generally use the Dewey system. The Cutter system and other types of classification are used to lesser degrees.

Table 7 describes the amount and type of cooperation existing between libraries surveyed. Formal interlibrary loan arrangements are the most frequent cooperative programs engaged in by the libraries interviewed. In addition, we found that the Western Region has begun central purchasing of supplies, union catalogs, and formal arrangements for ILL's and planning.

TABLE 2

LIBRARY USE STATISTICS

Library	Ratio of Circulation to Population	Ratio of Budget to Population	Book Budget as Percent of Total Budget	Personnel Budget as Percent of Total Budget	Ratio of Volumes Acquired per Year to Total Volumes	Ratio of Budget to Circulation	Ratio of Circulation to Volumes	Ratio of ILL's Borrowed to Total Circulation
Boston University	---	50	25.7	66.6	.05	---	---	---
University of Massachusetts	24	105	51.0	43.0	.17	4	.79	.01
Boston College	12	60	35.4	58.5	.04	5	.18	.00
Smith College	50	137	32.0	62.4	.03	3	.27	.02
Amherst College	---	---	34.8	61.1	.03	2	.32	.01
Salem State College	7	18	34.5	59.0	.17	3	.77	.00
Lasell Junior College	17	---	---	---	.09	---	.61	.00
Yale University	---	---	---	---	---	---	---	---
Hampshire Inter-Library Center	0.3	2	36.7	40.3	---	8	.25	---
Western Mass. Regional Library System	0.5	0.2	13.8	70.7	.18	1	5.18	.00
Worcester Public Library	---	---	10.0	75.0	.07	---	---	---
Massachusetts Film Cooperative	---	---	---	---	---	---	---	---
NASA	---	---	---	---	.32	---	---	---
General Electric Co.	---	---	16.3	35.7	.26	6	.68	---
Needham High School	13	13	38.2	61.8	.09	1	1.13	---
Phillips Academy	26	49	18.8	72.5	.02	2	.30	.00
Attleboro Public Library	---	---	15.7	54.1	.04	1	2.18	.00
Fitchburg Public Library	---	4	16.3	70.0	.12	---	---	---
Watertown Free Public	7	6	13.4	76.9	.06	1	2.21	.00
Forbes	9	5	16.9	66.2	.02	1	.93	.00
Springfield City Library	---	6	9.4	62.6	.09	---	---	---
Boston Public Library	4	6	13.93	78.87	.05	1	1.24	.00
Cotuit Public Library	18 (winter)	17	17.43	54.2	.06	0.97	.82	.01
	6 (summer)	6						

TABLE 3

INTERLIBRARY LOANS (ILL's)--EASTERN REGION

Library	Number of Volumes Held	ILL Requests Sent	ILL Requests Received	ILL's Received	ILL's Sent	ILL's Received From				ILL's Made To			Percent on Shelves When Requested	
						Public	School	College	Special	Public	School	College		Special
Lynn	NR	NR												
Watertown	128	151	60	126	43	X			X					51-75
Attleboro	82	86	0	13	0	X		X			X			NR
Cotuit	20	129		93										
Boston University	666	410	1,119	270	798			X			X			51-75
Salem State College	50	72	3	72	3	X		X		X	X			76-100
Boston College	665	302	198	143	171			X		X	X			76-100
Needham Public School	16							X	X		X			
Headquarters Boston Public	2,352	6	10,673	5	6,126									76-100
Andover Academy	81	35		26				X	X		X			
NASA	6	50	8	8-10	50									76-100
Lasell Junior College	20	0	0	0	0									

NR = No Record Available; X = Participates; Blank = Did Not Respond.

TABLE 4

INTERLIBRARY LOANS (ILL'S)--CENTRAL REGION

Library	Number of Volumes Held (M)	ILL Requests Sent	ILL Requests Received	ILL's Received	ILL's Sent	ILL's Received From			ILL's Made To			Percent on Shelves When Requested	
						Public	School	College	Special	Public	School		College
Fitchburg Public	111	2,816	5,181	441	2,809	X			X				51-75
Worcester Public	596	6,500	6,500	6,500	6,500	X		X	X				0-25

X = Participates

TABLE 5

INTERLIBRARY LOANS (ILL'S)--WESTERN REGION

Library	Number of Volumes Held (M)	ILL Requests Sent	ILL Requests Received	ILL's Received	ILL's Sent	ILL's Received From			ILL's Made To			Percent on Shelves When Requested
						Public	School	College	Special	Public	School	
Forbes	241	NR	4,844	923	6,701	X	X	X	X	X	X	51-75
Springfield	570	3,970	6,855	1,187	6,706	X	X	X	X	X	X	26-50
Headquarters Western	77	1,759	73	1,759	43			X		X		NR
Hampshire Inter- Library Center	27	NR	NR	NR	NR			X		X		76-100
Amherst College	383	3,000	5,000	1,618	2,523			X		X		NR
Smith College	500	NR	NR	2,185	2,107			X		X		76-100
General Electric	25	85	82						X		X	NR

NR = No Record Available; X = Participates; Blank = Did Not Respond.

TABLE 6

COMMUNICATIONS METHODS, RECIPROCAL ARRANGEMENTS, AND CLASSIFICATION SCHEMES

Library	Regional Code	Satisfied with ILL Program			ILL Request Forms Used			ILL Request Vehicle			Reciprocal Arrangements with Other Libraries			Classification Scheme Used							
		Yes	No	ALA	Title	Author	Subject	Other	Mail	Phone	Messenger	TSX	Other	Yes	No	Fees	Card Holders	Dewey	LC	Other	
Forbes	W	X		X		X		X					X								CC
Springfield Pub.	W	X		X		X		X					X								CC
Amherst College	W	X		X		X		X					X								
Smith College	W	X		X		X		X					X								X
HILC	W		X																		
University of Massachusetts	W	X		X		X		X					X								X
General Electric Headquarters	W	X		X		X		X					X								
Western Region	W	X		X		X		X					X								
Fitchburg	C		X			X		X					X								RF
Watertown	E		X			X		X					X								CC
Attleboro	E	X		X		X		X					X								
Cotuit	E			X		X		X					X								
Boston University	E	X		X		X		X					X								X
Boston College	E	X		X		X		X					X								X
Salem State College	E	X		X		X		X					X								X
NASA	E		X			X		X					X								X
Needham Public School	E	X		X		X		X					X								X
Phillips Andover	E	X		X		X		X					X								X
Headquarters				X		X		X					X								
Central Region	C			X		X		X					X								X
Headquarters				X		X		X					X								
Eastern Region	E	X		X		X		X					X								X

W = Western Region
 C = Central Region
 E = Eastern Region
 TS = Total Region
 RF = Regional Forms
 CC = Cutter Classification
 L = Restricted Privileges



TABLE 7

COOPERATIVE PROGRAMS

Library	Region	Type of Library	Storage		Acquisition		Cataloging		Central Purchasing		Union Catalog		ILL		Planning	
			Serials	Books	Serials	Books	Books	Serials	Serials	Books	Serials	Books	Serials	Other	Yes	No
Forbes	W	PE	X	X							X		X		X	
Springfield	W	P	X	X												
University of Massachusetts Headquarters	W	C							X		X		X		X	
Western Region	W	▲									X		X		X	
HILC	W	D	X			X					X		X		X	
Smith College	W	C	X	X		X					X		X			X
General Electric	W	*														X
Fitchburg	C	P	X	X		X					X		X		X	
Worcester	C	P	X	X					X				X			
Headquarters	C	▲	X	X							X		X		X	
Central Region	E	P														X
Watertown	E	P														X
Attleboro	E	P												X		X
Boston University	E	C											X		X	X
Boston College	E	C											X		X	X
Salem State College	E	C											X		X	X
Needham Public School	E	S														X
Lasell Junior College	E	C														X
Phillips Academy	E	S														X
NASA	E	C														X
Amherst	C	C	X	X		X					X		X			X

W = Western Region
 C = Central Region
 E = Eastern Region
 PE = Private
 P = Public
 C = College
 D = Deposit
 S = School
 * = Special
 ▲ = Regional Headquarters
 X = Agreement



TABLE 8

INDEPENDENCE--COOPERATIVE SYSTEMS

Library	Regional Code	Library Type	Will Lose Independence		Will Not Lose Independence		No Loss in Ability to Serve Local Readers with Either System
			System A	System B	System A	System B	
Forbes	W	PE		X	X		X
Springfield Public	W	P			X	X	X
Amherst College	W	C			X	X	
Smith College	W	C		X	X	X	
HILC	W	D		X	X		X
University of Massachusetts	W	C			X	X	X
Headquarters Western Region	W	▲			X	X	X
Fitchburg	C	P			X	X	X
Worcester Public	C	P			X	X	X
Headquarters Central Region	C	▲			X	X	X
Watertown	E	P	?	?	X	?	?
Attleboro	E	P		X	X		X
Boston University	E	C			X	X	X
Boston College	E	C		X	X		?
Salem State College	E	C		X	X		X
Simmons College	E	C					
Needham Public School	E	S		X	X	X	
Lasell Junior College	E	C			X	X	X
NASA	E	*		X	X	X	
Headquarters Eastern Region	E	▲			X	X	X
General Electric	W	*		X	X	X	

W = Western Region
 C = Central Region
 E = Eastern Region

PE = Private
 P = Public
 C = College

D = Deposit
 S = School
 * = Special

▲ = Regional Headquarters
 X = Agreement
 ? = No Opinion

Table 8 gives the librarians' reactions to suggested forms of future cooperation. System A would involve some kind of union catalog but no common acquisition planning. System B would involve common acquisition planning, as well as union cataloging. The table indicates that no library feared a loss of independence under System A but some feared a loss of independence under System B. Almost all libraries felt that they would not lose their ability to serve local readers under System A; a majority felt the same way about System B.

3. Analysis of Substantive Issues

A number of the questions dealt with topics which cannot be statistically analyzed. Our aim was to establish a range of possibilities which would reflect the total picture across the state. These questions are considered below.

a. Use of Interlibrary Loan

More than 2,000 libraries of varying size and function are located in Massachusetts. The libraries interviewed were among the largest and most active. If our sampling is indicative of state-wide trends, and we believe it is, one can assume that most collections are relatively small and that each library contains only a fraction of the total number of books and periodicals in print. With publishing activity increasing each year, it will become increasingly difficult for individual libraries to keep pace with the proliferation of printed matter. To properly serve the public, an efficient system of interlibrary loan will be required. Such a system does not seem to exist in Massachusetts at this time; a comparison of the Massachusetts and New York systems illustrates this fact. The library network in New York State, which serves 16,782,304 people, averages about 750,000 transactions per year in the interloan program. Massachusetts, with 5,148,578 population figure, should have at least 250,000 interloans per year, but interloan activity does not even approach this figure.

Figure 1 compares the number of volumes held by the libraries interviewed with the number of ILL transactions in which they engaged. Since these are among the most active libraries in the state, it can be assumed that a complete view of the state would result in large increases in holdings, and relatively minor increases in ILL activity. Thus, though local circulation may be reasonably good, a rich potential of library use is being neglected because of insufficient interloan activity.

b. Types of Clients Generating Interlibrary Loan Requests

In the interviews, we asked librarians to characterize the users who generate interlibrary loan requests, and the reasons (general reading, adult education, research, hobbies, business, or industrial information) they make requests. The largest single category of users, both for public and college libraries, was college students, graduate and undergraduate. The second largest group was college and university faculty. A considerable number of adults who are not connected with colleges also make requests for interlibrary loans. In a few cases, industrial or business users turn to their public libraries. A few libraries also reported that high school students are given the privilege of making ILL requests, though libraries in general are reluctant to furnish the interlibrary loan service to the latter group. While the American Library Association frowns upon use of ILL by undergraduates, the increase in independent research required by schools is beginning to make this a necessary aspect of library service. Most libraries reported that interlibrary loan requesters need the books and serials for research purposes. Very few report use of ILL for general reading, adult education, hobbies, or business information.

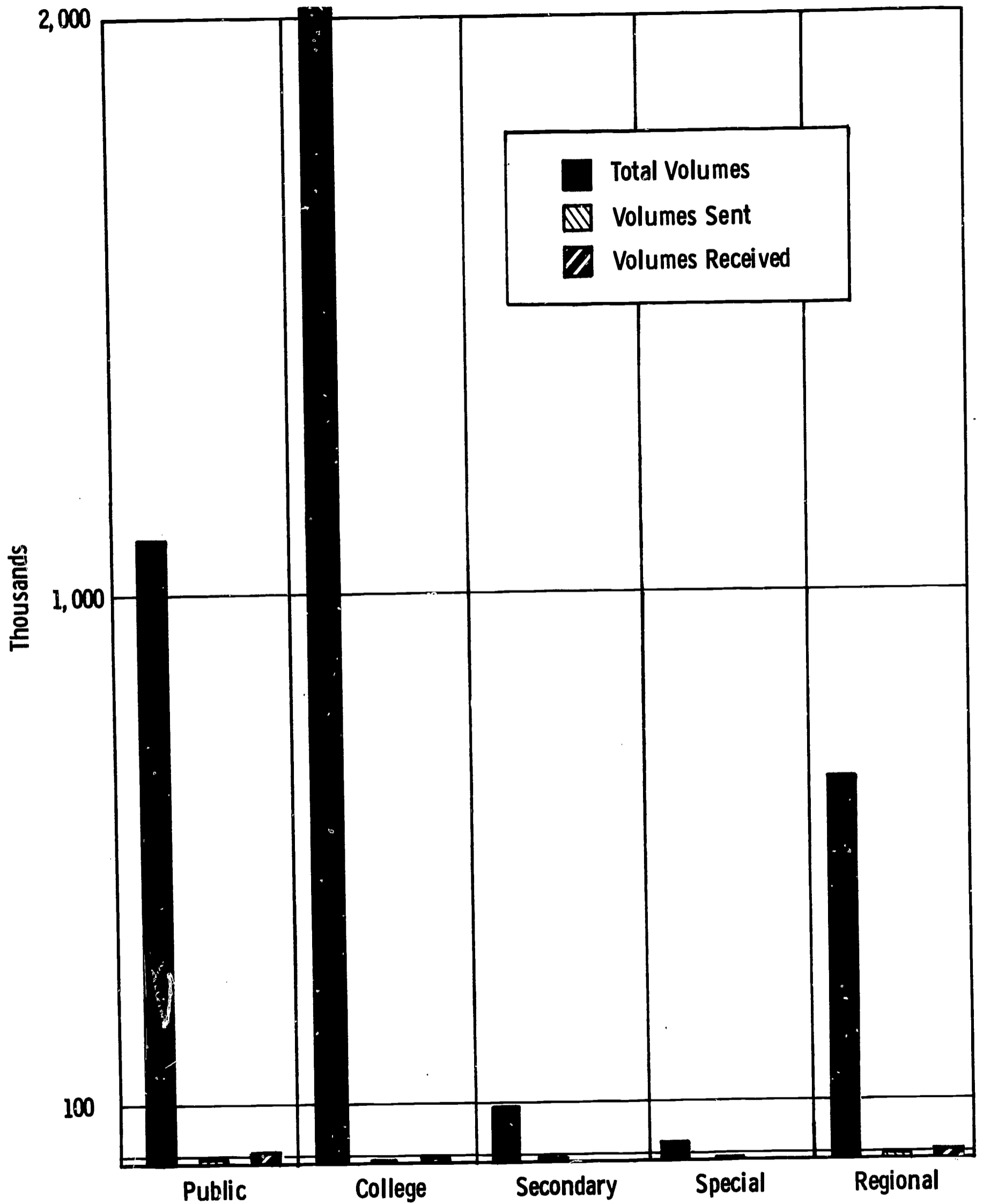

FIGURE 1 TOTAL VOLUMES VS INTERLIBRARY LOANS SENT AND RECEIVED

Interlibrary loans undoubtedly would increase if the system were faster and if inventory tools in the form of union catalogs and union lists of serials were available to make the location of material more efficient. In an expanded program, interloan requests probably should be placed on data processing cards so that they can be related to the activity of the computer more easily. We believe that too little is expected of the libraries as far as ILL is concerned, with the result that a degree of complacency exists with regard to the current level of performance. The National Union Catalog provides a very useful tool for the researcher and serious student. Unfortunately, it is inadequate for the needs of the general public. The ALA code also may prove to be inadequate for public libraries. The present criteria used to decide whether or not a patron's request should be turned into an interlibrary loan is that the request must be serious in nature. In public libraries, at least, this criteria should be altered to include any reasonable request; the public should have greater access to a network financed by state and federal funds. A housewife needing material on braiding a rug should be no less welcome to the interlibrary loan network than the graduate student or the professional man.

Librarians were also asked what percentage of patrons' requests for materials which were not in the reporting library became interloan requests. The resulting figures varied widely from library to library. For example, the Lasell College Library made no interlibrary loan requests for its students; instead, students are sent to the Newton Public Library where they all have cards or to the Boston Public Library. Other libraries have a ratio as low as 1% of interlibrary loan requests to user requests unanswerable within the library. The library at the NASA Research Center indicated that for 90% of the requested publications not on its shelves it either makes interlibrary loan requests or encourages its professionals and top management to use their own library cards at Harvard and MIT.

c. Time Requirements for ILL Service

From the data collected, it is evident that the time requirement depends on the individual case. Students generally require material as quickly as it can be made available; college faculty seem to be less concerned with speed; and the general public very seldom requires immediate service. However, the faster the service the more likely it is to be used. In industrial libraries (e.g., General Electric, ADL, NASA), time is a critical factor because the requestor may be working under severe time limitations. In certain special libraries, teletype is used to locate a book quickly and messenger service employed to retrieve it. While some types of users are less concerned with speed than others, librarians generally indicated that their readers like to have the material quickly, if possible. By averaging the time requirements noted by our interviewers, it can be estimated that 50% of the users want the requested materials within one week. In answering ILL requests, it may take a month to locate a relatively specialized out-of-print publication; more common materials can be located in three days to seven days, or slightly longer. When the requestors use libraries which depend on mail communications, the waiting time is, of course, greater than it is at libraries which use telephone, teletype, or special messengers.

d. Specialization

In the interest of developing a more efficient ILL system (perhaps without recourse to a union catalog) in which certain libraries could be identified as major resources for a particular subject or subjects, we asked each library to list the major areas of specialization covered in their collections. Only 12 of the libraries interviewed responded to this question, suggesting that the others have broad collections which do not cover one field in depth. More than half of the 12 respondents were college or special libraries.

It is to be expected that colleges granting graduate degrees will have material in depth in the graduate fields. It is also to be expected that special libraries will cater to the specific needs of their clients. On the public library level, however, it was hoped that there would also be some specialization. Among the public libraries responding, each indicated that local history and/or genealogy was covered in some depth. These fields, of course, would be of limited interest to other libraries. Only four other areas were mentioned by public libraries: art, two libraries; music, one library; material on Calvin Coolidge, one library; and social sciences, one library.

In most cases, when local readers require more specialized information, the libraries attempt to borrow from colleges. This service is one of the primary functions of the inter-library loan system. Public libraries, being supported by taxes, are expected to serve the needs of the public, while colleges are supported by private funds and must serve their own students. A need is indicated for cooperative purchasing and the building of subject strengths. If, in addition to its general collection, each public library were to develop one area in depth, the burden of ILL for the public could be lifted from the university level, except for highly specialized material.

e. Reciprocity of Access

Another of the substantive issues concerned the reciprocity of access between libraries; that is, who is allowed to use a library in addition to its regular patrons. Some libraries extend borrowing privileges to persons having cards at other libraries; others extend only reading privileges. Reciprocal arrangements are as varied as the different kinds of public served by each type of library. The following is a summation of the responses to the questionnaire on this issue.

Amherst College extends reading privileges to students from the University of Massachusetts, Smith College, Mt. Holyoke, and other neighboring colleges. Borrowing privileges are extended to the faculty of the neighboring colleges. The residents of Amherst are not given borrowing privileges at the college, but members of the Honor Society at the Amherst High School may be extended borrowing and reading privileges when they are seniors. The remainder of the high school population cannot use the Amherst College library. Space, file security and discipline are the reasons given for such restrictions.

The library in *Attleboro*, Massachusetts operates on an informal agreement with the surrounding towns, extending free cards to 1500 to 2000 borrowers.

Boston Public Library is beginning to accept card holders from any library in the state. About 20,000 nonresident borrowers are expected to be registered by the end of this year.

Boston University extends free access to anyone who wants to use the library. It assumes that anyone who will take the trouble to come to its library and register for a borrower's card is seriously interested in using the library and should be allowed to do so. Because of its status in Boston, Boston University feels that its library should be open to the general public. The establishment of a new MBTA stop near its new facility may encourage more of the general public to come in. The university would stop its free access policy if it ever prevented the library from fulfilling its primary function of offering service to B.U. students, but this is not anticipated in the near future.

The *Central Region* is administered by the Worcester Public Library, which is the headquarters for the Central Massachusetts Regional Library System (CMRLS), and by a regional library at Fitchburg. The region contains 68 member libraries, and card holders in the region have access to any library in the CMRLS. The headquarters library at Worcester also extends borrowing privileges to card holders from other parts of the state.

The *Cotuit Public Library* encourages card holders of the Barnstable System (seven libraries in the town of Barnstable) and other Cape Cod residents to use its facility. Reading privileges are extended, but residents are encouraged to buy a membership in the library association (local) in which they have borrowing privileges.

The *Hampshire Interlibrary Center Headquarters (HILC)*, a jointly owned research collection used to supplement the library holdings of the member institutions which share equally in providing financial support, had an estimated 22,908 card holders in 1966, plus the members of the Western Massachusetts Regional Public Library System (WMRPLS). HILC extends full services to 5,477 card holders from the supporting institutions which includes all students and faculty from Mount Holyoke, Smith College, and the University of Massachusetts. As the local regional library of the WMRPLS, Forbes Library in Northampton has an associate membership and pays \$5750 in fees. There are no individual member fees.

Lasell Junior College has no reciprocal arrangements and does not extend borrowing privileges to the general public.

The Massachusetts Film Library Cooperative was formed to fill a growing need for good audiovisual materials in the schools, libraries, regional libraries, and state colleges. Each library depositing films which it has bought is allowed to borrow freely from those films purchased by all member libraries and may borrow school-owned and state-owned films (at previously set rental prices) up to the amount contributed. At the conclusion of each bookkeeping period, each library receives two bills (in addition to the rental fee) each for 5% of the total charges. One bill is payable directly to the cooperative society for self-insurance and repairs on the films; the other is payable directly to the Commonwealth of Massachusetts for administrative charges. Schools and libraries which are not members of the cooperative can rent films at the predetermined rental fee.

NASA in Cambridge opens its library to the public on a restricted basis. Borrowing by the general public is not permitted, and fees are not involved. Space restrictions limit the number of people who can be served. Anyone can use books which cannot be obtained in public libraries. Professors and scientists working on NASA projects may borrow from this library.

Needham High School Library has no reciprocal arrangements, but does provide free access to its stacks.

Phillips Andover Academy extends borrowing privileges to card holders from the Memorial Hall Library in Andover. Fees are not involved. The academy is willing to give access to anyone other than a secondary school student and a college undergraduate. This restriction was imposed because the library was being drained by students from other schools.

Salem State College offers free use of its stacks (not borrowing) to all college students on the North Shore. Salem residents (primarily high school students) are not allowed to use the library because of space limitations. Most outside students use the library during the exam period and for term paper research. Students at Salem State College, in return, are able to use the Salem Public Library and the Library of Essex Institute.

Smith College extends privileges to faculty and graduate students from other universities. Fees are not involved.

The *Springfield Public Library* extends borrowing privileges to nonresidents for \$5/year and to out-of-state residents for \$10/year. Free cards are issued to students attending colleges in Springfield, military personnel at Westover Air Force Base, clergy, anyone who pays city taxes, and members of the Springfield Municipal Library Activities Association. The regional system extends borrowing privileges to card holders from any library in the system, but the public library facilities perform the processing and control activities, as well as provide the collection. Member libraries unable to acquire sizable collections can obtain books from the regional library via ILL; the books are delivered by bookmobile and distributed by the member library. The regional system considers this arrangement a reciprocal arrangement, but it might more properly be considered interlibrary loan.

The *University of Massachusetts* requires college identification cards. Regular library cards are not issued. Students at other colleges in the area may use the library and borrow materials by special request and through ILL. No attempt is made to serve the general public. Students from the four HILC colleges also have access to the library.

The *Watertown Public Library* is open to all card holders. Cards are issued to town employees who reside in other towns. In 1967, six nonresidents who desired access to the library paid a \$7.00 fee. This policy is being dropped; no fee will be involved in the future.

Within the state, reciprocal borrowing privileges via a universal borrower's card should be recognized by all libraries. Throughout the country, this service barrier is being eliminated. In New York State, for example, membership in a public library system requires by state law that each member honor its system's plan for reciprocal borrowing. Compacts are also developing among systems in New York, and a state-wide plan will soon become a reality.

Reciprocal borrowing opens the door to better service to library patrons within the state. In practice, few hardships result from reciprocal arrangements among public libraries. The fear of being overrun with nonresident borrowers has, with few exceptions, proven to be without foundation. When problems do develop, special contracts can ease the burden.

Unlike public libraries, colleges and universities have a relatively restricted service mission - to serve their particular students and faculty. Many are beginning to become more community-oriented and, to a degree, material in college and university libraries is available to the students, regardless of school affiliation. At the present time, there seems to be no need to do more than encourage the trend.

C. PRESENT STATUS AND RECOMMENDATIONS BY TYPE OF LIBRARY

1. Public Libraries

"Every individual has a right to benefit from the record of what is known, whether he lives in a big city, a suburban community, a small town, an unincorporated area, or a rural district. Even though local resources are limited, public officials and librarians have the responsibility for providing access to full library service, through a suitable and effective structure of cooperation and government."*

Few librarians would disagree with this statement. It represents the broad aims of all public library service. Consideration of this statement raises some questions about library activity in Massachusetts. Has the aim of library personnel been accomplished?

The Regional Library System, with headquarters libraries serving the Eastern, Central, and Western portions of the state, was established to facilitate the flow of public library materials within the state. In some instances, initial steps have been taken to improve local service and increase the use of ILL. But, much remains to be done. More readers must be made aware of the ILL services open to them; reference services must be improved; communication and delivery systems must be faster; and better use must be made of resources within the state but outside a particular region. In short, public library service must be improved in many ways to bring more material within the reach of more people in the most efficient way possible.

We recommend that the present regional libraries retain their function as resource centers, and continue to offer free access to persons living within the regions and consultant service. To fulfill the technical service and information retrieval needs of the libraries in the state, three new regional headquarters should be established, entirely separate from the large public libraries which may be located in the same city. This separateness will clarify their administrative organization and remove undue burdens from the staffs of the present large libraries associated with the regions. The new regional headquarters should be under the direct supervision of the Library Service Center (see Section D) to be operated by the Bureau of Library Extension.

* "Standards of Quality for Public Library Service," a draft report of the Basic Committee on Standards, ALA, p. 1.

The functions of the State Library Service Center and of the regional headquarters, as related to public libraries, will be as follows:

a. Interlibrary Loan

(1) Locating Material. The state center will maintain a union catalog of holdings throughout the state, and this catalog will be continuously updated. During the initial stages of the program, the computer will print out each month a list of holdings within each region; this list will be sent to the appropriate regional headquarters. When a local library wants a book on ILL, it will telephone the regional headquarters, which will then check the catalog. If the book is located within the region, the headquarters will contact the holding library to determine its availability. If the book is not listed in the regional catalog, the headquarters will teletype the request to the state center which will then locate the book. As the file grows and the searching load builds up, the master file should be arranged by region, and the discs searched at the regional headquarters.

(2) Delivery. To provide the next step in the ILL process, we recommend that each regional headquarters maintain truck delivery service to all libraries within its area. Having determined that a book is available at a given library, the truck will pick up the book and deliver it to the requesting library. The trucks should be equipped with two-way radios so that if the holding library is within a truck's route that day, the headquarters can notify the driver to stop at the holding library. Otherwise, the library will be scheduled for the following day's trip. Likewise, if the requesting library is on that route, the book can be delivered the same day. In any case, no more than three days will elapse between origination of the request and the receipt of a book available within the region.

When a request has to go through the State Library Service Center, a similar truck delivery system should be used. The center will contact the holding library to determine the book's availability. The headquarters of the region within which that library is located will then be notified by the center and will retrieve the book. If the holding region is next to the requesting region, it will deliver the book to the latter; if not, the holding region will deliver the book to the next closest region, which will pass it on to the requesting region, which will give it to the local library. This procedure will require 3 to 6 days, assuming the book is available when requested.

The geographical area of Massachusetts is such that, if each region maintains 3 to 6 trucks, all portions of the state can be covered adequately. The trucks also will be used to deliver processed books (to be discussed below). The trucks' routes will be determined according to which libraries are scheduled for delivery and by the ILL requests made the day before.

b. Book Processing

We recommend that libraries send book orders to the State Library Service Center, which, in turn, will send orders to the vendors. Because of geographical considerations, vendors will be asked to deliver to the three regional service centers. While the regional service

centers are waiting for the books, the state center will prepare catalog cards (using MARC tapes when they become available) according to acceptable library standards (both LC and Dewey classification systems will be offered). These cards will then be either sent to the regional service center or, more likely, printed out on smaller supporting units at the regional service centers. When the books arrive, they will be processed by the regional service center, matched with the appropriate cards, and sent to the ordering libraries. Only a few days should elapse between receipt of the book at the regional center and its delivery to the local library.

A charge should be made for this service to each participating agency (not only public libraries would be involved) on the basis of cost per unit processed. This cost should be sufficient to balance off the actual costs incurred by each of the three regional service centers. These centers will provide other services in addition to processing, but only that portion of the costs relating to processing should be passed on. The cost of the State Library Service Center itself should be absorbed by the state.

During the first year of operation, the regional service centers should establish a flat charge of, perhaps, \$1/book, to absorb any losses that might accrue within the year. This charge should be made until volume reaches the mass production level, probably one year. Expenses related to organization of the centers also will have to be absorbed. At the end of one year, the computation of the charge per unit processed should be based on a figure which experience will indicate actually reflects costs incurred by the centers. Use of the computer to prepare catalog cards, data collection devices to control the flow of processing materials, inventories, and a businesslike approach to the operation should keep unit costs at a level which will be acceptable to most of the libraries in the state.

c. Communications

Each regional center should obtain a credit card telephone number so that local libraries will feel free to call whenever necessary. To provide quick communication with the state center and other regional centers, each regional center also should be equipped with a teletype installation.

It is hoped that the assumption of ordering, cataloging, processing, and interlibrary loan functions by the state center and its subsidiary regional centers will free local librarians of many of the routine aspects of library administration and provide them with more time to devote to direct service to readers in the form of reference assistance, special programs, stimulating reader interest, etc.

2. College and University Libraries

Higher education in the United States is expanding rapidly. New campuses are being opened, and established schools are growing at a rapid rate. In Massachusetts in 1956, there were 74 institutions of higher education, having a total enrollment of about 120,000.

By 1964, there were 95 institutions with well over 180,000 students enrolled. As enrollment rises each year, librarians find themselves faced with the need to provide more research material for more students with increasingly specialized interests. The publishing world reflects an accompanying information explosion - more than 30,000 titles were published in the United States during the past year.

The colleges and universities in the state are looked to as the major library resources for both historic and current information. Smaller colleges and those concerned solely with undergraduate education do not maintain as extensive collections as the larger institutions. Institutions offering graduate programs must attempt to offer both broad and deep resources in the fields concerned. The greater the specialization, the more extensive will be the library resources provided. The largest collection in the state, and one of the largest in the world, is that of Harvard University. Its entire collection (including the libraries of the various graduate schools) numbers more than 7.6 million books and periodicals. It is estimated that this figure will reach 10 million by 1974. Massachusetts is fortunate to have the resources of this institution.

Even Harvard, however, cannot hope to keep up with the present growth of knowledge. As stated in the 1965 - 1966 Annual Report of the University Library, "It should be emphasized that a policy of maintaining strong collections is not a policy of isolation or self-sufficiency; the Library will continue to call upon other institutions for help in providing what is needed by Harvard scholars." This statement points up the fact that while colleges often find themselves in the position of giving assistance to others, they too are interested in the benefits of cooperation.

To have a viable plan for library activity in the state, all types of libraries must be encompassed, including those of the colleges and universities. Degree of participation, however, will vary according to the size and type of institution involved. Possible modes of participation are discussed below.

a. Centralized Ordering, Cataloging, and Processing

Small colleges with limited staff and funds will probably want to take part in this aspect of the state library network. Participation would be coordinated through regional offices of the State Library Service Center.

b. Union Catalog

Because of the effort and expense involved in operating a union catalog, the largest college libraries will not be expected to contribute. Many of the resources of major college libraries can be located through the National Union Catalog. It would be most helpful, however, if the smaller schools and state colleges provided information on their holdings to the central information bank. This information would facilitate their own search for material and would help to shift the burden of interlibrary loan from the major resource libraries to the smaller libraries, which now receive only a minor portion of ILL requests.

c. Interlibrary Loan

It is hoped that all college libraries will want to participate in the ILL service through the State Library Service Center. Through the use of computers and other automated equipment, location of material will be rapid and the time lapse between request and receipt will be considerably shortened.

d. Resource Libraries

Those universities and special libraries which maintain extensive and specialized material will be regarded as resource libraries. In searching for ILL material, only those requests which cannot be handled elsewhere in the state but are likely to be filled by the resource libraries will be channeled to these collections. A fee of \$10,000/year plus \$2.00/search (regardless of success) should be paid by the state network for this assistance. The state university and the Massachusetts State Library should be regarded as resource libraries and be reimbursed for searches. The State Library cannot at this time be a truly effective resource unit but should be considered as one by virtue of the unique aspect of its collection. Hopefully, this library will be reorganized and strengthened in the near future.

3. School Libraries

The needs and activities of school libraries (elementary and secondary) are quite different from those of public libraries. They serve a specialized clientele, supplementing the textbooks and classroom instruction offered in the schools. Unlike many other states, school libraries in Massachusetts are even more independent of each other than local public libraries, since they come under the jurisdiction of local school committees. Localism has tended to produce isolation. Schools in one town may institute creative and worthwhile projects, but schools in neighboring towns are usually unable to share in these assets. A town may consider itself in competition with its neighbors, which results in wasteful duplication, misuse of talents, dissipation of energies, etc.

School libraries could benefit greatly from a state-wide cooperative system. They are, in general, quite small and have limited resources, funds, and personnel from which to draw. Most barely meet the minimum national standards and will probably not be able to meet the new standards which are expected shortly.

a. Special Instructional Material

New educational methods and materials are being developed and tested every day. In the realm of school libraries, new developments include the extensive use of nonbook material in addition to traditional library resources. Such learning aids as films, filmstrips, tapes, records, puzzles, games, maps, science materials, programmed instructional guides, objects from nature, and all forms of realia are becoming necessary items in a forward-looking school library. Information on school libraries in Massachusetts, however, indicates little involvement with these new concepts of learning. One hindrance, of course, to adding these new

materials to school collections is lack of sufficient funds. Wholesale acquisition of new media would be costly, especially of materials requiring special equipment, such as projectors and tape recorders. Two methods of dealing with this problem are:

- Establishing a single resource center for school libraries, connected with the State Library Service Center, and
- Establishing regional school library resource centers.

If the first method were adopted, the state center could purchase a bank of special materials and equipment. Schools could borrow materials from the center as needed. It would be assumed that these schools would also be willing to lend whatever resources they had. Local schools would be encouraged to add to their own collections and to use the resources of the center on an interim basis and for specialized equipment.

The second method would provide for regional centers (possibly five) across the state. The exact number and location of the centers would be determined on the basis of geography and number of school districts. The region should contain enough schools to make the center economically feasible, but should not cover too large an area; it should be easily accessible to each participating school. The regional centers would purchase special instructional materials on behalf of all the participants. Funding would be from the State Department of Education. The resources of the centers would be available to each school: (1) on a rotational basis, (2) by reserving certain material in advance for a specified time period, or (3) by coming directly to the center and selecting materials from its open collection. If the regional concept is used, local schools would not necessarily be encouraged to buy highly specialized or expensive tools finding occasional use. Emphasis would be on audiovisual materials and other nonbook media.

While both plans would work, we recommend the latter as a means of fostering greater interschool cooperation, as well as making more materials available with greater ease and speed to more schools. In either case, the resource center or centers would be under the jurisdiction of the Bureau of Library Extension.

b. Book Processing

Except in the largest libraries, cataloging and processing activities constitute a major drain on a librarian's time and energies. They are routine functions, but they demand continual attention as new material is added to the collection. In school libraries, use of time for book processing is a critical factor, since the library staff often consists of the one librarian and, perhaps, one or two student aids. In some cases, the librarian must perform teaching duties in addition to providing regular library service and reference assistance to students and teachers.

To remove this burden of routine activity, we recommend that school libraries be encouraged to use the State Library Service Center. The three regional processing centers for all types of libraries will serve the schools. Orders again would be sent to the state center;

books would be received, cataloged, processed, and sent out from the appropriate regional office. Because of the initial difficulties involved in establishing a centralized processing network, only book material should be processed during the first year of operation. Non-book material should be added to the processing activities after the centers' procedures have been established.

c. Consultant Services and Seminars

The Bureau of Library Extension should add at least two or three school library consultants.*These persons should be chosen on the basis of experience and, more importantly, their ability to think creatively about the problems of school libraries and possible solutions. They should have a thorough knowledge of the field, a sense of innovation, and the ability to project ideas to other people with tact and understanding.

One aspect of the consultants' activities would be assistance in book selection. The bureau should build a demonstration collection of bibliographic tools, review copies, and prepublication items. New material should be held at the bureau for a month, then sent to each of the special resource centers for a week for the convenience of local school librarians. After the rotation period, the books may be either added to the demonstration collection or distributed to weaker school libraries. Each year \$25,000 should be allocated for the development of the demonstration collection. The consultants should also train participating school librarians in the use of book selection tools and in the development of effective book selection criteria.

As part of the consultant program, a continuing schedule of in-service training courses should be developed. These should be held in various parts of the state and led by the state consultants or by other persons with experience in the particular subjects to be covered. The present system in which local librarians meet to discuss new books, etc., should be continued, but these seminars should be chaired by persons with special expertise. Emphasis should still be on the sharing of ideas and experience, but a resource leader should help to direct the discussion and suggest creative solutions.

The courses should cover a wide range of school library activities such as:

- (1) Library participation in planning and developing curricula,
- (2) Methods of stimulating interest in the school library, in addition to serving those students who already use the library on their own initiative,
- (3) Use of technology,
- (4) Factors involved in selection of book and nonbook material,
- (5) Criteria for self-evaluation,
- (6) Interaction of school and public libraries,
- (7) The library's function as an integral part of the educational process, rather than an adjunct to it.

*Filling existing vacancies would be adequate.

- (8) Means of making the library more readily available to students,
- (9) Methods of developing research techniques among students, and
- (10) The uses and effects of various media.

d. Professional Collections

The Bureau of Library Extension should ensure that an extensive collection of educational materials and literature is maintained in the state for use of all teachers and administrators. Until the bureau can strengthen its own collection, it should work cooperatively with the few libraries in the state which have good education collections. The existence of the collection should be well-publicized, and teachers throughout the state should be encouraged to borrow from it through ILL.

In addition, and perhaps even more urgent, the five school resource centers should develop strong education collections as quickly as possible, with necessary duplication of more significant titles. The collections should be accessible to local school teachers and administrators on ILL.

We also recommend the development in the long term of professional collections within the individual school libraries. It will take time to develop such collections, and many schools will be unable to cope with the project financially. Even if the suggested ratio of books to staff were to parallel that of books to students, a small school would still have only a small number of books for the use of staff. The Boston area is, perhaps, more fortunate in this regard than are other parts of the state. In Boston are located the Simmons School of Library Science, the Harvard Graduate School of Education, the Boston Public Library (with an education collection of 6000 to 8000 books and 200 periodicals), and the library of the Boston School Committee (with about 12,000 volumes).

3. Special Libraries

The range of libraries which can be termed "special" is large. We use the term to denote libraries operated by companies and those operated by government agencies, for example, NASA and the Massachusetts State Library. (Institutional libraries are considered in a separate section.)

Of the libraries considered in this study, special libraries serve the most homogeneous clientele. Their collections are limited to areas which are particularly appropriate to their users. In most cases, their holdings consist of business and financial material, or scientific and technological data. Periodicals often constitute a major resource, since their users must keep pace with the most current developments in their fields. A medium-sized company like ADL, for example, subscribes to approximately 2000 periodicals.

Concomitant with need for up-to-date information is the importance of speed when material is sought from an outside source. When requesting items on interlibrary loan,

special libraries usually use telecommunications rather than the mail and often will employ special messengers to retrieve a book, periodical, or photocopy once its availability has been determined.

Special libraries generally use ILL extensively. Although they concentrate their resources in particular subject areas, they recognize that their collections must be supplemented by those of other libraries for information which is needed only on an occasional basis. Unfortunately, the ILL traffic is primarily in one direction. Because industrial libraries are designed to have material at the immediate disposal of their own clientele, they are reluctant to lend material to other organizations. However, they are usually willing to photocopy pertinent information if the user will pay the copying charge.

In many ways, other libraries in the state can learn from the practices and experience of special libraries. The emphasis on speed and efficiency, the use of modern communication methods, the concept of specialization in depth, and the extensive use of ILL are noteworthy aspects of special library service.

Special libraries also can gain from an improved library system in Massachusetts, primarily in the area of information retrieval (i.e., the rapid location of specific data through use of the computerized union catalog). Special libraries may take part in the processing activities of the State Service Center, but this would probably be only for standard publications. In its later stages, the center may be able to handle government publications and other specialized material, which would be of value to special libraries.

For more immediate benefits, we recommend that special libraries be encouraged to contribute to the union catalog, listings of those materials which they would be willing to lend on ILL. (Of course, certain of the special libraries' documents are restricted to in-company use.) They should also provide a listing of material which would be available for photocopy. In return, they would have access to the union catalog located at the State Service Center, which would enable them to locate rapidly desired information and eliminate the need to contact several resource libraries to locate material.

D. RECOMMENDED STATE SYSTEM

1. Organizational Structure

Figure 2 shows the suggested organizational structure of the state library network. The following organizational reforms have been incorporated in the structure shown.

(a) Responsibility for the entire state library program should be vested in the Bureau of Library Extension.

(b) As an extension of the Bureau of Library Extension, a State Library Service Center should be created to be responsible for maintaining a union catalog and union list of serials; information retrieval and ordering of library materials; maintaining a demonstration school collection and a professional education collection; maintaining a special materials center for institutions; and coordinating materials for the handicapped.

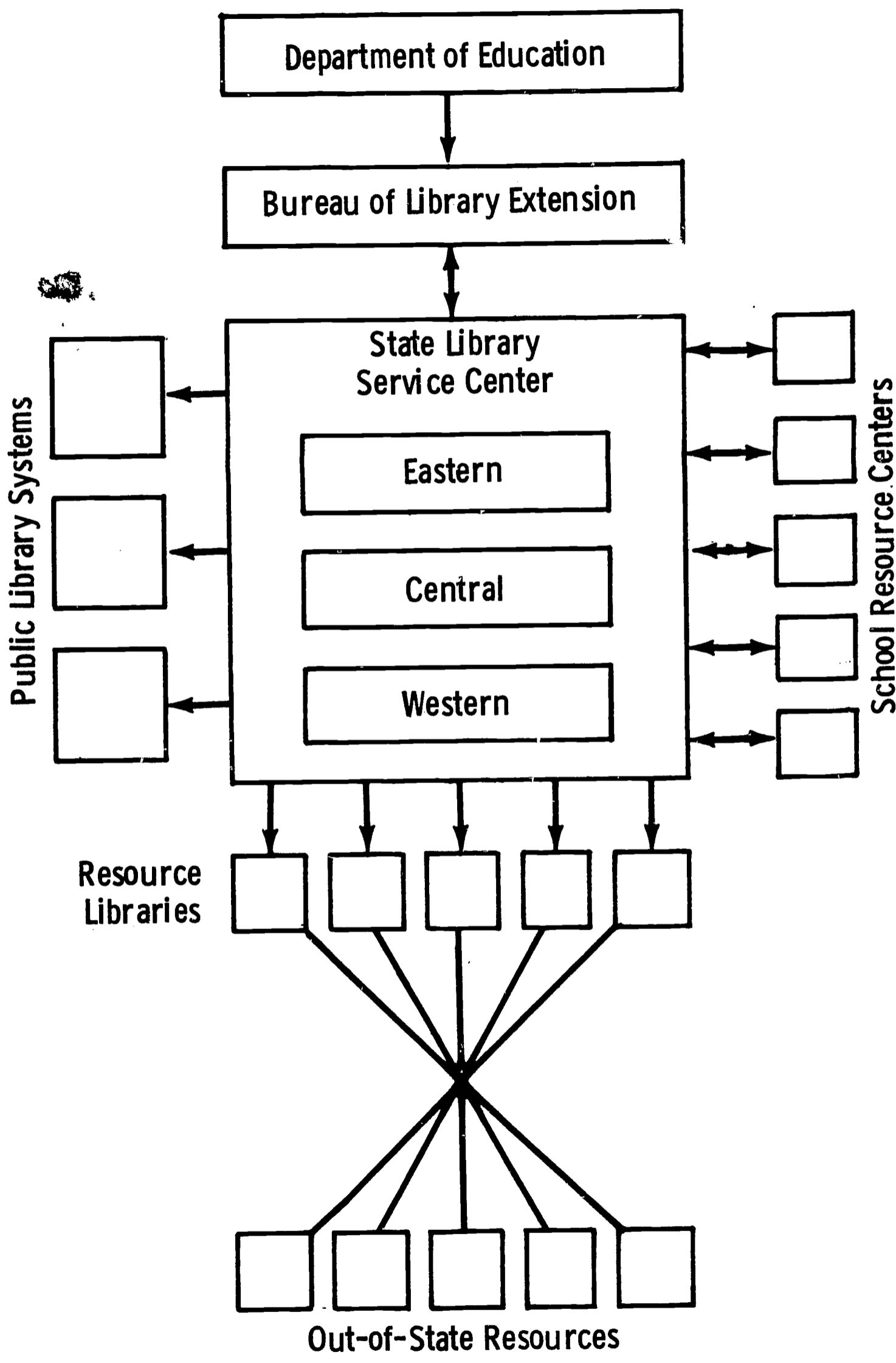

FIGURE 2 ORGANIZATION STRUCTURE OF STATE LIBRARY NETWORK

(c) Under the state service center, three regional service headquarters responsible for technical activities should be created.

(d) Regional school library resource centers, perhaps five, should be established; the exact number will depend on demonstrated need. The centers would be funded and administered by the state. An advisory committee of school librarians may be appropriate.

(e) The large resource libraries of the state should be attached to the service center in an associative role. These would be funded by the state through an annual grant and also through fees charged for services. A library would be chosen as a resource library on the basis of extent of holdings and the likelihood of having materials unavailable anywhere else. The Bureau of Library Extension would decide which libraries would qualify; the following should certainly be included.

College and Special Libraries:

Harvard University,
Massachusetts Institute of Technology,
University of Massachusetts,
Hampshire Interlibrary Center, and
State Library.

Public Libraries:

Boston Public Library,
Springfield Public Library, and
Worcester Public Library.

The three public libraries are included because they provide extensive resource service. Although they are serving as the headquarters of regional systems, they have never become true systems. When the new program is developed, they should act as resource libraries but also have some responsibility for providing free access and area consultant programs within their respective regions.

2. Personnel

To provide the necessary services, the Bureau of Library Extension will require the services of ten additional professional librarians (exclusive of staff for the State Library Service Center). An equal number of clerical staff should be provided to support the professional staff members. The additional professional staff would include the following:

- (a) Two professional librarians to provide consultant services to institutional libraries. They would oversee this portion of the state-wide program and would build special collections to provide a bank of specialized material for institutional libraries. (See Section III.)

- (b) Two professional librarians to provide consultant service to the handicapped and institutions serving the handicapped. They would oversee this portion of the state-wide program and would build a special collection of materials needed for handicapped persons. In addition, they would be responsible for coordinating the ILL program as it relates to the handicapped. (See Section IV.)
- (c) An assistant director with one assistant to supervise the activities of the state service center. The assistant director and his assistant should be a college graduate with a master's degree and experience in computer use. He need not be a librarian.
- (d) Two professional librarians to provide consulting services to school libraries. They would oversee this portion of the state-wide program and guide the establishment and operation of the five regional school resource centers (providing nonbook materials).
- (e) An assistant director with one assistant to handle interlibrary activities. They would prepare funding requests and would be responsible for relations with the federal government. Both should be professional librarians.

The State Library Service Center will require the services of the following:

- (a) Director (professional librarian),
- (b) Assistant director (computer specialist),
- (c) Assistant director (librarian),
- (d) Two reference librarians,
- (e) Two catalogers,
- (f) Assistant to the director, for information services,
- (g) Two senior tab operators,
- (h) Computer programmer,
- (i) Four key punch operators,
- (j) Business manager,
- (k) Assistant to the business manager,
- (l) Eighteen clerk typists and secretaries,
- (m) Three maintenance men, etc.,
- (n) Four delivery men, and
- (o) Part-time help.

The regional headquarters, which will be established after the service center is functioning will have staffs similar to, but smaller than, that of the service center.

School resource centers will require the following personnel:

- (a) Director (professional librarian),
- (b) Assistant director for resources (professional librarian),
- (c) Reference librarian, and
- (d) Eight to ten clerks.

3. Budget

It is not possible to detail actual funding requirements with a high degree of accuracy. However, general estimates must be made to provide guidelines for administrative decisions. We recommend the appropriation of the following additional funds for the fully implemented program:

(a) Bureau of Library Extension	
Twenty additional personnel, other costs (including expenses and facilities)	\$350,000
(b) State Library Service Center	
State Center	650,000
Regional Headquarters	
Eastern	250,000
Central	250,000
Western	250,000
(c) Five school centers (\$200,000 each)	1,000,000
(d) Service to institutions	250,000
(e) Service to the handicapped	250,000
(f) Special contracts	<u>250,000</u>
Total	\$3,500,000*

The funding would include new state monies and funds forthcoming under the Library Services and Construction Act of 1966, Titles III, IV-A, and IV-B. We recommend that full funding be available at the end of a four-year period. During the first year, 25% would be made available, and an additional 25% would be made available each succeeding year, until the full amount was reached.

Table 9 shows that total program funds under Title III could be \$125,000 for fiscal year 1967, \$394,000 for fiscal year 1968, and up to \$823,600 for fiscal year 1971. These figures were compiled from the program description, which indicates a flat allocation of \$40,000 per fiscal year to each state, with additional monies distributed on the basis of each state's share of the national population in the last decennial census. Each state must match federally contributed funds, except in 1967.

*An additional \$500,000 should be allotted to allow for increases in cost if modest delays occur in the implementation of the program.

TABLE 9

**AUTHORIZED FUNDING UNDER TITLE III--
LIBRARY COOPERATION
(thousands of dollars)**

	Fiscal Year				
	1967	1968	1969	1970	1971
Total federal funding	5,000	7,500	10,000	12,500	15,000
Flat allotment	2,000	2,000	21,000	2,000	2,000
Funding according to population	3,000	5,500	8,000	10,500	13,000
Massachusetts share, according to population*	85	157	228	300	371.8
Massachusetts share of flat allotments	40	40	40	40	40
Total Federal allotment to Massachusetts	125	197	268	340	411.8
Massachusetts funds to match federal funds	0	197	268	340	411.8
Total program funds		394	536	680	823.6

*Massachusetts 1960 population, 5.16 million was 2.86% of national population in 1960.

Source: Library Services and Construction Act Amendments of 1966, Public Law 89-511, approved July 19, 1966.

Table 10 shows the amount of federal funds which will be allocated to Massachusetts under Title IV-A. Massachusetts funds must match federal funds except in 1967. If the maximum of federal funds is given and matched by state funds, the potential of the program rises from about \$125,800 for fiscal year 1967 to \$935,000 for fiscal year 1971.

We estimate that about 30,000 people are in institutions either wholly operated by the state or receiving funds from the state. All these institutions should be eligible for funds under Title IV-A. We recommend the expenditure of \$20/institutionalized person, or \$600,000 for fiscal year 1969. Each institution would contribute \$5/person and the Bureau of Library Extension would contribute \$15/person from state funds and federal funds.

Table 11 shows Massachusetts and federal money authorized under Title IV-B. Massachusetts funds would be greater than the maximum potential federal allotment, because the matching formula is based on the ratio of state per capita income to national per capita income. The money authorized for the program increases from \$75,000 for fiscal year 1967 to \$430,100 for fiscal year 1971.

We estimate that in fiscal year 1968 there will be about 5200 handicapped users, including 2600 blind persons. If the state continues to allocate \$16/user, state funds will make up about \$83,000 of the required Massachusetts matching funds needed (\$104,000) to receive the maximum potential federal allotment for fiscal year 1968. For fiscal year 1969, we estimate that there will be about 7800 handicapped users. If the state continues to allot \$16/user, state-supplied funds will be about \$125,000; again, state funding is less than required matching funds (\$168,000) for maximum federal allotment for fiscal year 1969. We recommend that the state continue to allocate \$16/user to the Regional Library for the Blind and provide the additional funds needed to secure maximum federal allotment.

To implement the entire program recommended in this report, \$3.5 to \$4 million dollars may be required. The state should make up the difference between federal funds received and the total funds required to implement the program.

4. Changes in Legislation

Legislation will have to be enacted to provide additional funds necessary for an improved program of library service to the entire population of the state. The Board of Library Commissioners is already vested with the authority to implement most of the recommendations. The legality of the operation of the processing centers and the relationships with vendors should be explored carefully, in conjunction with the legal department of the state.

We recognize that our report calls for a substantial effort on the part of the state. Several other states, including California, New York, Michigan, and Illinois, have already adopted state-wide plans, which are substantial in scope. Massachusetts lacks an effective state-wide library plan. Implementation of the recommendations outlined in this report should provide Massachusetts with an effective instrument to cope with current and future needs. Action is needed now if Massachusetts is to fulfill its responsibility of providing an effective library structure for its citizens.

TABLE 10

**AUTHORIZED FUNDING UNDER TITLE IV-A--
LIBRARY SERVICE TO INSTITUTIONS
(thousands of dollars)**

	Fiscal Year				
	1967	1968	1969	1970	1971
Total Federal Funding	5,000	7,500	10,000	12,500	15,000
Total Federal Allotments to Massachusetts ^a	125.8	197.3	268.8	340.3	411.8
Massachusetts Funds to Match Federal Funds ^b	0	250.7	341.5	432.4	523.2
Total Program Funds	125.8	448	610.3	772.7	935

- a. Massachusetts 1960 population, 5.16 million, was 2.86% of national population in 1960.
- b. State percent share of total funds bears the same relation to 50% as the ratio of Massachusetts per capita income to U.S. per capita income. Thus, Massachusetts funds are 55.96% of total program funds. The income ratio is based, by law, on the "three most recent consecutive years for which satisfactory data are available from the Department of Commerce."

Source: Library Services and Construction Act Amendments of 1966, Public Law 89-511, approved July 19, 1966.

TABLE 11

**AUTHORIZED FUNDING UNDER TITLE IV-B--
LIBRARY SERVICE TO THE HANDICAPPED
(thousands of dollars)**

	1967	1968	Fiscal Year 1969	1970	1971
Total federal funding	3,000	4,000	5,000	6,000	7,000
Flat allotments	1,250	1,250	1,250	1,250	1,250
Divided According to Population	1,750	2,750	3,750	4,750	5,750
Massachusetts share, according to population ^a	50	78.6	107.2	135.8	164.4
Massachusetts share, flat allotments	25	25	25	25	25
Total federal allotments to Massachusetts	75	103.6	132.6	160.8	189.4
Massachusetts funds to match federal funds ^b	0	131.6	168.5	204.3	240.7
Total program funds	75	235.2	301.1	365.1	430.1

- a. Massachusetts 1960 population, 5.16 million, was 2.86% of national population in 1960.
- b. State percent share of total funds bears the same relation to 50% as the ratio of Massachusetts per capita income to U.S. per capita income. Thus, Massachusetts funds are 55.96% of total program funds. The income ratio is based on the "three most recent consecutive years for which satisfactory data are available from the Department of Commerce."

Source: Library Services and Construction Act Amendments of 1966, Public Law 89-511, approved July 19, 1966.

III. LIBRARY SERVICES TO INSTITUTIONS

A. THE PRESENT SITUATION

The institutions and special schools operated or partially supported by the state maintain varying degrees of library activity. Some have no official library at all; others have as many as four libraries, each with a distinct purpose. Each institution and special school needs its own library facilities, but the exact nature of the library resources must be dictated by specific objectives and programs of that institution, as well as by the special problems of the institutionalized.*

To establish criteria and to develop recommendations for appropriate library resources for institutions and special schools, we have studied: (1) the characteristics of the institutionalized; (2) the objectives and programs of institutions and special schools; and (3) existing library services within the framework of three basic institutional objectives--rehabilitation, education, and custody. Libraries for the institutionalized and for professional staffs are considered separately, since they have quite different functions and, in fact, exist as separate entities in the majority of institutions surveyed.

1. Institutionalized Users of Libraries

The total institutionalized population can be considered a cross-section of the general population. All ages, economic, social, and educational backgrounds are represented. The important difference is that the institutionalized have special problems which prevent them from using the general services and resources provided by the state, such as public libraries and schools.

When discussing the general characteristics and special problems of the institutionalized as they pertain to library services, it is helpful to divide the institutionalized into three groups:

- (1) The mentally retarded and emotionally disturbed,
- (2) The physically handicapped, and
- (3) The socially maladjusted and isolated.

Although it is recognized that mental, physical, and social problems frequently occur in combination, institutions and special schools are established according to these basic groupings. These groups have differing requirements for library materials. Except for the prevalence of speech defects among the retarded, the mentally retarded and emotionally disturbed are essentially free of physical impairment. The physically handicapped are distinguished from the first group because, theoretically, they have normal mental capabilities. The socially maladjusted and isolated are not necessarily mentally or physically

*For purposes of this report, "institutionalized" includes day students at special schools.

impaired; this group includes adolescents and adults who are institutionalized because of difficulties with the law and adults who have no place in the community. A brief discussion of the general characteristics of the three groups, emphasizing similarities and dissimilarities, follows.

a. Age Range

Considered together, these groups contain all ages. Some special schools are confined to definite age ranges similar to public schools. The socially maladjusted group does not include infants or young children.

b. Intelligence

All levels of intelligence are represented in each group, with the exception of the mentally retarded.

c. Education

Education level attained ranges from elementary to graduate in all groups, with the majority at the lower levels since problems of physical impairment and difficulty in dwelling in the community frequently are associated with educational retardation and dropping out of school. For the group of mentally retarded attending special schools, it is obvious that the educational level attainable is extremely limited. This fact does not necessarily apply to the emotionally disturbed or physically handicapped.

d. Reason for Institutionalization

The essential reason for institutionalization of all three groups is inability to live or be educated normally in the community. Whether this inability stems from retardation, emotional disturbance, physical impairment, social maladjustment or old age, special facilities are required to care for or house these people.

e. Degree of Institutionalization

A large proportion of the persons in these groups are totally institutionalized, and all are completely dependent on the various institutions, even if they attend by day, live in only a few months, or have privileges to leave for work or social reasons.

f. Average Length of Stay

Many of these people are institutionalized for life, although they may move from one institution to another (e.g., transfer from the Massachusetts Hospital School to the Rutland Heights Hospital upon completion of the eight grades of schooling given by the

former). In other instances, particularly in correctional institutions, the length of stay may be only a few months, but the incidence of return is high. However, this return rate is being offset by a decided shift in emphasis to rehabilitative efforts, rather than punitive or merely holding efforts. Whenever possible, the retarded, disturbed, and handicapped stay in the community or return to it. Examples of this trend are the mentally retarded attending the newer rehabilitation centers and the disturbed persons who receive out-patient treatment at mental health centers after perhaps a brief hospitalization.

g. Special Problems Affecting Use of Library Services

It is in the area of special problems affecting their use of library services that these three groups differ the most; yet their needs are similar. All, but especially those permanently confined to institutions, need library materials of a very high interest level, and library resources which will kindle or rekindle their interest in the programs provided for them or in some aspect of the world around them. To sustain and build this interest, the institutions housing these groups and special schools and centers educating and/or rehabilitating them desperately need all the tools that a library can provide. The blind require verbal material in specialized form. The mentally and educationally retarded need high-interest low-vocabulary material. It is difficult for a fourteen- or twenty-year-old student in the second grade to be interested in reading material provided for the normal second-grade student. The problem becomes more acute when grades have been repeated. Likewise, it is difficult for a mentally retarded adult to read for enjoyment material which has not been specially prepared for his or her reading and interest level. The physically incapacitated have difficulty holding books and magazines, and those who are completely bedridden or immobilized must have the library resources brought to them. The aged have failing eyesight and cannot read normal print. All of these problems in the use of library resources suggest the provision of highly specialized materials to fulfill the great need of these groups for good library service.

2. Libraries for the Institutionalized

Despite the wide variety of student, inmate or patient problems, the types of institutions being considered can be categorized on the basis of three primary objectives and programs:

- (a) Rehabilitative: rehabilitation centers for the mentally retarded, correctional institutions, and mental health centers;
- (b) Educational: all schools for the physically handicapped (the blind, the deaf, and crippled children) and for emotionally disturbed children; and
- (c) Custodial: correctional institutions, domiciles and hospitals for the chronically ill, aged and/or severely retarded and crippled.

Some institutions fall into more than one category. For example, correctional institutions have been listed as both rehabilitative and custodial because increasing emphasis is being placed on rehabilitation, particularly by schools under the Youth Service Board. It could also be argued that many of the special schools in the educational category are in a sense rehabilitative; their primary purpose, however, is to educate children who, for one reason or another, are unable to attend public schools. The above-named categories are helpful in determining library resources needed to supplement the three types of institutional objectives and programs.

Six of the ten institutions surveyed had libraries for the institutionalized (the school principal took care of one); one had a staff library only; and three had no official library. However, the existence of a library by no means implies that it is either adequate or appropriate for the institutional population it serves. Existing libraries are quite similar in that their book collections are composed mainly of donations and are, therefore, largely unplanned second-hand collections of popular fiction. They are usually crowded and dreary, although centrally located. A few of the library rooms, however, are fairly pleasant approximations of small public libraries, reflecting the care and interest they receive as focal points within institutions. In some instances—notably in special schools—they are, or are about to be, housed in new buildings so that the physical aspects will be considerably better. The library facilities frequently serve nonlibrary purposes, such as providing meeting space for board members or classroom space for music lessons; thus their availability for reading is decreased.

a. Staff

None of the seven institutions and special schools which had libraries had a professionally trained librarian. A few of those acting as librarians had been certified as junior assistant librarians; all seven had mastered, through experience and investigation on their own, a sufficient amount of library technique to enable them to handle their respective libraries. Six of the seven also took care of the staff library. Three had once been assisted by a professionally trained librarian for a few days.

The seven librarians had different educational backgrounds and work experience. Some had prior library experience; some had taught or been certified to teach; some had taken jobs after raising families; and one had held a clerical position until recently. In two instances, the librarians had previously worked in another capacity at the same institution.

The one quality these people have in common is a personal involvement with the institutionalized, and a desire to help them. They are frequently included with staff members in general meetings and serve on committees concerned with therapy and progress toward institutional goals. One librarian has a major responsibility as liaison between volunteers and inmates.

b. Collections

As might be expected in library collections composed primarily of donations, the selections are chiefly older fiction, popular magazines, and newspapers. Not cataloged, but frequently very much a part of the library resources, are thousands of paperbacks. Books discarded by public libraries, other hospitals, and private schools represent a substantial portion of existing collections. The main deficiencies are in the areas of nonfiction and reference material. Special schools are more apt to have collections somewhat better suited to the needs of their students, since they obtain funds from other sources as well as from the state, including the federal government (through the Elementary and Secondary Education Act), parents, trustees, and religious orders.

Table 12 gives data on collections and institutional populations and shows 1966 expenditures and sources of funds. Circulation information is not included because records are inadequate, since loan periods are not as rigidly defined or adhered to as they are in regular libraries. Also, as mentioned above, paperbacks are not cataloged.

Interlibrary loan plays only a very small part in augmenting library resources for the institutionalized. Infrequently, librarians visit their local public libraries or the Boston Public Library to obtain on their own cards specially requested items or more current fiction for the few more avid readers.

c. Nonwritten Materials and Special Equipment

The libraries surveyed had very modest holdings of nonwritten materials and special equipment, if any. The responsibility for providing special materials and equipment is undefined; such items fall somewhat in the province of those concerned with education or physical therapy. Apparently, the latter has more to do with equipment to enable a handicapped person to read, such as page-turners. It is, therefore, relatively impossible to discover via library channels how many pieces of such equipment there are and how great the need for them is. Many institutionalized handicapped are unable to read even with the aid of special equipment.

Audiovisual equipment, for which the responsibility is also unclear, is in short supply and is generally considered in the province of education and library services. Private special schools more frequently possess equipment, as shown in Table 11. A great need for this equipment is expressed, particularly by institutions and rehabilitation centers dealing with the retarded. Most are making attempts to obtain records and to borrow films; this is the only real use they attempt to make of interlibrary loan.

d. Budgets

In the libraries surveyed, expenditures per institutionalized person for books and periodicals ranged from \$0 to \$6.25 in 1966. Table 11 indicates that amounts and sources of funds vary widely and that librarians of special schools augment their budgets with funds from sources other than the state. Unfortunately, these tend to be nonrecurring gifts.

TABLE 12

CHARACTERISTICS OF SURVEYED INSTITUTIONAL LIBRARIES

OBJECTIVE*	INSTITUTION A C (A,B)	INSTITUTION B B (Private)	INSTITUTION C A
Library for Institutionalized	No (room with books used only by elementary school students)	Yes	No (room with inappropriate books)
Number of Institutionalized	1,832 (356 elementary students)	67	197
Age Range	Infancy through old age	6-16	16-26
Number of Hard Cover Volumes	Approximately 350	800	None appropriate
Number of Serials	None	3	None appropriate
1966 Expenditures (other than staff salaries)	0	\$419.09	0
Source	State Supply Account for Education and Recreation	Title III, \$131.09 Parents' Guild \$288	State
Library for Professional Staff	Yes--small departmentalized (OT, Nurses, School, etc.)	Yes	No
Number of Bound Volumes	Approximately 240 (25 in teachers' library)	20	0 ?
Number of Serials	?	8	Few (somewhat inappropriate)
1966 Expenditures (other than staff salaries)	?	?	?
Source	Parents' Assoc. for teachers' library Others: state ?	?	State
Equipment	School has television in book room, at least 1 tape recorder, 1 sound projector, 1 opaque projector, 1 record player. New grant will provide more.	School has 4 tape recorders, 4 record players, 3 head sets, 2 language masters, 1 projector, 1 viewer.	School has 1 sound projector and 1 tape recorder.

TABLE 12 (Continued)

OBJECTIVE*	INSTITUTION D C (A)	INSTITUTION E A (B)	INSTITUTION F A
Library for Institutionalized	Yes	Not yet (classes taken to rooms with books; getting librarian for summer)	No (has book cart)
Number of Institutionalized	135	322	225 (+4,000 outpatient)
Age Range	17-80	11-17	4-0ld age
Number of Hard Cover Volumes	6,750	Approximately 2,000	0
Number of Serials	20	Approximately 20	0
1966 Expenditures (other than staff salaries)	\$240 (staff library accessions and supplies included)	\$640	0
Source	State-share hospital budget	Title II	--
Library for Professional Staff	Yes, but not separate	No	Yes
Number of Bound Volumes	250	Few	5,600
Number of Serials	6-8	?	2,800
1966 Expenditures (other than staff salaries)	?(included above)	?	Approximately \$2,100 (and portion of \$1,000 gift)
Source	State-share hospital budget	?	State-journals (\$1,500) & some books (\$200) Auxiliary: \$400 (in addition to special gift)
Equipment	School has none; school dept. has 1 tape recorder	School has 1 projector	Library has 1 microfilm viewer.

TABLE 12 (Continued)

OBJECTIVE*	INSTITUTION B	INSTITUTION H C	INSTITUTION I C
Library for Institutionalized	Yes	Yes	Yes
Number of Institutionalized	180	175	825-850
Age Range	4-21	18-20 to old age	Aged
Number of Hard Cover Volumes	Approximately 1,500	5,366	Approximately 5,000
Number of Serials	Approximately 20	Many (all donations)	Many
1966 Expenditures (other than staff salaries)	\$400 + (possibly \$800)	0 ?	Less than \$500
Source	State: \$200+ specially requested encyclopedias, etc. Title II: \$200 and part of special trustee's grant of \$1,100	State	State-07 account
Library for Professional Staff	Yes	Yes	Yes
Number of Bound Volumes	Approximately 1,000 (including bound periodicals)	445	500
Number of Serials	32	73	All that are necessary
1966 Expenditures (other than staff salaries)	?	\$1,177 (7/1/66-6/1/67)	\$2,000
Source	Medical director purchases ?	State-budget account unknown (requested \$1,792 and has not received \$500 for binding)	State-07 and other account
Equipment	School Dept. has (closed circuit television and probably some other).	Library has 1 slow-speed player (for talking books). Hospital has tape recorder and record player (?).	1 microfilm printer (worn out) in medical library

TABLE 12 (Continued)

**INSTITUTION J
B (Private)**

OBJECTIVE*

Library for Institutionalized	Yes
Number of Institutionalized	290-300
Age Range	4½ - 17
Number of Hard Cover Volumes	Approximately 3,200
Number of Serials	Several
1966 Expenditures (other than staff salaries)	? (\$500 exclusive of federal and state aid)
Source	State, federal government, and private
Library for Professional Staff	Yes (not separate)
Number of Bound Volumes	800
Number of Serials	Several
1966 Expenditures (other than staff salaries)	? Included above
Source	State and Private ?
Equipment	Library has 5 or 6 different types of projectors, 2 tape recorders, 1 television.

* Institutional Objective Designations: A=Rehabilitative; B=Educational; C=Custodial. Objectives in parentheses are secondary.

There seem to be some differences among institutions as to stated annual budgets and requests for specific items which may or may not be honored. Decisions concerning what will be spent on libraries, whether expenditures will be for the institutionalized or for staff, and what account the money will actually come from rest largely with the head and/or steward of each institution. Certain librarians have relatively little control over expenditures; others go to great lengths to secure bargains, stretching a fixed amount as far as possible and frequently contributing not only their time but also their personal funds to the cause.

e. Function

In educational institutions, libraries serve the same function that any school library would serve—to provide reading materials to supplement courses of instruction. In addition, however, these libraries are study areas, sources of recreational reading, and, to a certain extent, social centers.

Fewer rehabilitative institutions have libraries, and the library resources which do exist are used infrequently for instructional purposes or recreational reading. Of course, certain institutions in this category have many nonresidents, who presumably have access to their local public libraries and whose family livingrooms fulfill the other needs being met by institutional libraries.

In custodial institutions, libraries serve a dual purpose. They are the public libraries for the institutionalized and, in some cases, they are the only leisure area to which residents can go to read a newspaper or a magazine.

f. Use

Use of libraries by the institutionalized depends greatly on the functions described above. The amount of use corresponds somewhat to the amount of use any given smaller community makes of its public library. For some, it is only a place to sit on a bad day. For others, it is the only available source of books needed in conjunction with their studies. In every group, there are avid readers. Use of the library for reading depends on the availability of appropriate materials—for the mentally retarded must be provided specially prepared high-interest low-vocabulary book or audiovisual materials not currently available; for the physically incapacitated, the book cart. Also, the incidence of book damage is high because of the inability of the patients, in many cases, to handle the books correctly.

A very important factor in use is accessibility. The extreme of this factor is having no library at all; but, even where there are libraries, the hours are limited and the libraries are often preempted for other purposes during the hours when they are supposed to be open. Accessibility is extremely important in institutions where residents have no place to keep materials they might otherwise borrow from a library.

3. Libraries for Professional Staff

In general, libraries for the professional staffs are adequate in institutions and special schools which have objectives established over a period of time, additional sources of funds, and/or ready access to other libraries with in-depth collections in desired fields. The most deficient in terms of staff libraries are the newer rehabilitation centers for the retarded and the institutions where emphasis has shifted to rehabilitation.

One librarian interviewed supported his decision to use available funds for acquisitions for the staff library rather than for the patients' library, with the statement: "What better way to use funds designated for the welfare of patients than to educate their doctors!" From a practical aspect, limited funds have commonly had to be used for the acquisition of current medical and psychological reference materials, which are not likely to be donated.

The professional staff libraries are frequently in rooms adjoining the other libraries, unless they are medical libraries located in hospital buildings apart from domiciliary areas for the institutionalized. Smaller staff collections may be either located in the library for the institutionalized or divided into separate areas for doctors, nurses, administration, etc. and scattered around the institution.

a. Staff

Librarians usually handle both types of library, but they often serve only as custodians of the libraries for professional staff. The lack of information which can be obtained from librarians regarding expenditures and sources of funds (see Table 12) reflects their purely custodial status. In one institution which maintained only a staff library, intensive teaching and research programs are being carried out, necessitating a full-time librarian and also more use of interlibrary loan and copying services.

b. Collections

Existing collections for professional staff contain current reference material and journals in fields related to the care of the institutionalized. In hospitals, collections consist of a core library of medical reference books and journals, use being made of other library sources for research purposes. Various current materials pertaining to the special child, alcoholism, teaching the deaf, rehabilitation, etc. are available in other institutions.

The size of the collections in the institutions surveyed, together with some indications of 1966 expenditures, are shown in Table 12. With one exception, the institutions lacking a library for the institutionalized also lack officially designated staff libraries.

c. Special Equipment

The institutions had little microfilm equipment. Of the libraries surveyed, one had a worn-out microfilm printer, and a second had one new viewer.

d. Budgets

Amounts spent on libraries for professional staffs vary widely. Presumably, only the state provides the funds. Some institutions are struggling to find funds for any sort of library. Others manage to cover the needs of their professional staff through skill and experience in selecting barely enough of just the right material. In most institutions, the director, medical director, or a library committee determines what acquisitions will be made, after reviewing staff requests. Serials, however, apparently are ordered at the state level and at least some institutions feel the items sent them are not as good as they would be if the institutions involved had some voice in the selection process.

e. Function

Staff libraries are used for reference purposes by the regular staff and by students in the numerous training programs conducted in conjunction with local colleges and universities. In general, books and journals are not circulated. Use of interlibrary loans to augment collections is infrequent, since staff members usually obtain material not found in these libraries on their own.

f. Use

The professional staffs in the institutions surveyed make good use of their libraries. The reference material contained in these libraries is necessary in the care of the institutionalized.. Access to the libraries is unlimited, but use is greatest at night.

B. FUTURE LIBRARY SERVICES TO INSTITUTIONS

1. Librarians

a. Training

Future library service to institutions should provide that professional library staff at the state level work with institutional librarians and aid in the planning and financing of library resources (for both the institutionalized and the professional staffs) suited to the particular needs of the three basic institutional programs and objectives.

Everyone involved in library service is aware of the extreme shortage of trained personnel. Nowhere is this felt more acutely than in institutions. Until this shortage is alleviated, we recommend professional guidance from the state level, particularly while nonprofessionals continue to staff the institution libraries. Librarians must be familiar with each of the major departments at the state level involved in service to institutions. If they are not, the much needed bibliotherapy program will fail. In addition, every effort should be made to recruit a professional librarian for each individual institution, particularly for the larger or independent institutions. One need only look to the success of the Veterans' Administration library program to see what can be gained through vigorous bibliotherapy work.

If additional funds for the expansion of services are not forthcoming in the near future, an educated person with sufficient motivation toward service to the institutionalized may be able to handle the activities of the library. As additional resources become available, in-service courses will help provide the necessary additional skills. A correspondence course for workers in institutional libraries and a handbook for guidance in practical matters would be extremely valuable.

b. Responsibility at State Level

Two staff positions at the Bureau of Library Extension should be created for specialists in institutional libraries. They would:

- (1) Visit the various institutions in the state and work with the library personnel in the definition of goals, selection of materials, and improvement of service;
- (2) Be responsible for correspondence courses, bulletins, newsletters, etc., which would instruct institution library personnel in library techniques and make available pertinent information concerning facilities, funds, books, and other services offered either by the Bureau of Library Extension or the federal government;
- (3) Maintain a loan collection; and
- (4) Maintain liaison with the State Library Service Center to make available to institutional libraries the materials available through the ILL network and reference program.

In addition to the consultants for institutional libraries, provision should be made for sufficient supporting staff to allow them to carry out the above duties adequately and efficiently. Salaries of these personnel would be paid by the Bureau of Library Extension; the salaries of librarians at the institutions would continue to be paid by the institutions. To provide good library service, the bureau also must be responsible for some of the funding, training, selection of appropriate materials, cooperation among libraries, ILL to augment present collections, and the formation and maintenance of a suggested bank of audiovisual materials.

2. Libraries for the Institutionalized

Libraries for the institutionalized should be established where they do not exist. All existing libraries should be reviewed in light of the institutional populations they serve and the functions they fulfill within the framework of the three types of institutional objectives and programs: educational, rehabilitative, and custodial. Each institution should have appropriate library resources; careful planning and consideration of specific purposes will be required to develop these facilities.

The libraries in the institutions surveyed should be given proper status in the hospital organizational structure. Professional librarians should be recruited. A reasonable portion of the total educational budget should be assigned regularly to the library. The collection should be selected professionally, not made up of donations of unimportant and useless material. To attract patients and inmates who are not readers by nature emphasis should be placed on paperbacks and periodicals. Interlibrary loan should be available through the state library network to patients as well as to staff. The librarian should be an important member of the rehabilitation team which seeks to expedite the improvement and even discharge of patients and inmates through all possible means, including bibliotherapy. None of the hospitals and institutions surveyed had an effective bibliotherapeutic program, despite the efforts of some of the librarians.

a. Books

Each institutional library needs a more appropriate collection of books. Our survey highlighted the inadequacies of libraries for the mentally and educationally retarded; donated books are inappropriate. Educational and rehabilitative institutions should definitely have top priority in obtaining materials to implement their objectives. Educational institutions also must have reference materials for institutionalized students.

Custodial institution libraries should be geared to kindling and sustaining some spark of interest in the world for those who have little else to rely on. Where appropriate, these libraries also should have special materials, for example, large print books for those with failing eyesight and high-interest low-vocabulary books for the retarded.

b. Audiovisual Materials

Our survey indicated that institutional libraries have insufficient audiovisual equipment and materials. Educational and rehabilitative programs can use this material, particularly with the mentally retarded. Custodial institutions also can use audiovisual aids in giving some service to the severely crippled and bedridden. The aged with poor eyesight and many of the handicapped need the special materials and services created for the blind.

In the use of specialized equipment, it is possible to conceive either of groups listening to talking books or individuals using headsets. A great deal of learning reinforcement and entertainment, otherwise lost to the institutionalized, can be provided by audiovisual means. Television cannot fill the gap for the retarded or for those who would read if they were physically able to do so.

We recommend that a bank of appropriate films, slides, tapes, and recordings be established under the Department of Education, that catalogs be supplied to all institutions, and that a procedure be established for loaning the material on request, with free rapid delivery service. Equipment used with these audiovisual materials should also be distributed to the institutions. The existing bank of tapes for the blind (discussed in Section IV) might form the nucleus of this larger bank of audiovisual material to service all the institutionalized handicapped. Because of the great need for special materials, it is not advisable for institutional libraries to rely on public libraries for this service. Establishment of a state bank of material can provide a wider range of subjects at less expense than would be incurred on an individual library basis.

c. Service

Libraries for the institutionalized must have resources which can supplement the programs of institutions. The administration of each institution must accept or reject the premise that the library can and should participate strongly in: (1) the rehabilitation program for patients and inmates, and (2) the education and provision of professional information to staff. If the premise is accepted, no half-way measures will suffice. Staff, money, equipment, and liaison with the state network will be essential. Otherwise, the small, ineffectual custodial collections of rather useless reading material will remain.

Holdings need to be adjusted so that their true function as combination public libraries, school libraries, and/or sources of interest and recreation within the confines of an institution can indeed be realized. In addition to resources, accessibility is extremely important. The library should be at least as accessible as any public library. Book cart service to the bedridden is essential and should be extended to include nonbook material.

To satisfy the reading needs of the users, institutional librarians should make more use of ILL from local public libraries. Some of the users may not recognize their needs; the librarians must make them aware of these needs. It appears reasonable that each institutional librarian should request, at regular intervals, a modest amount of reading material from local public libraries, in addition to the books specifically requested by patients.

d. Budget

Expenditures for library services to the institutionalized should be high. A per capita annual expenditure of \$20 would improve these services substantially. We recommend that the expenditure of \$20/institutionalized person/year consist of matching funds—\$5 from the institution and \$5 from the Bureau of Library Extension; an additional \$5/institutionalized person should be spent by the bureau to build up the materials bank and \$5/person for special grants. The bureau funds should be provided, on a matching basis, from both state and federal funds. The bureau should have the right to withhold the \$5/person grant and the materials from an institution if the institution does not spend at least \$5/person from its own funds or does not properly use the granted funds.

We realize that \$20/person is much more than the present library expenditure for the noninstitutionalized. We believe that the following factors justify the expenditure:

- (1) The expenditure for library services in institutions has been extremely low in the past, as Table 11 indicates. It will take years of concentrated effort to make up for the previous lack of expenditures;
- (2) Library services make up one of the few "windows on the world" available to the institutionalized; the services, if available, could assume a much greater importance for them;
- (3) The institutionalized have much more free time than the rest of the population; and
- (4) Many of the institutionalized need special and expensive library materials (e.g., audiovisual materials).

Because of these over-riding needs, we believe that the \$20/capita allocations should be increased when additional funds are available so that services can be extended and the depth of coverage of existing services increased. Initially, special grants are needed to provide libraries where there are none. The need for new libraries will increase with the establishment of more rehabilitation and mental health centers.

Institutional library budgets should be established and controlled by the departments responsible for the institutions, and library funds should be kept separate from other funds to ensure their use for the designated purpose. Matching funds should be contributed at the state level initially to build the recommended bank of nonbook material. As an indication of the amount of money required to build such a bank, consider that expenditure of about \$25,000 annually would be needed to start a good film library. At the institutional level, there is little apparent use or awareness of the sources of various types of free material from publishers, Library of Congress, etc. which, presumably, the state would obtain and distribute.

Institutions must keep better track of funds used for libraries than they do now, so that accurate fiscal count can be kept of library funds contributed by the state, which will count toward the matching funds supplied by the federal government. We believe that the state will have to spend additional funds to obtain the minimum federal funds; to obtain maximum federal funds the state will have to allocate considerable additional funds. These funds have been assumed in the program suggested.

3. Libraries for Professional Staffs

Although comparatively more adequate than those for the institutionalized, the libraries for professional staffs are deficient in many instances. The extent of deficiency varies with the type of institution, its location, the length of time the institution and/or library has existed, the objectives of the institution, the staff size, the number of professional fields and disciplines involved in the care of the institutionalized, and the amount of participation by other agencies and schools.

a. Book Material and Function

Collections must provide current reference material needed to further the objectives of each institution. The most deficient libraries are those in institutions oriented toward rehabilitation. The most adequate collections are found in the older institutions, primarily custodial institutions. New libraries must be established and each existing library must be reviewed to determine specific needs. It is extremely important that each institution have a voice in the selection of all its book material. Change in institutional objectives, amount of current research, and degree of innovation in disciplines involved vastly influence the adequacy of collections for reference purposes. Staff members should not be forced to use outside sources for the basic reference and training material which these institutional libraries are established to provide. Interlibrary loan systems and procedures should be used only for access to in-depth collections for research purposes.

b. Microfilm Equipment

Libraries for professional staff should have microfilm reader-printers because certain journal articles and doctoral dissertations are available only on microfilm.

c. Budget

Separate provision should be made for professional staff libraries, within the library budgets. Institutions lacking staff libraries should have priority. Criteria should be established for purchasing items—needed current reference materials should be purchased; initially, the purchase of additional desirable, but nonessential items, should be deferred.

IV. LIBRARY SERVICES FOR THE HANDICAPPED

A. PRESENT SITUATION

1. Organizations and Programs

Many organizations serve the handicapped, but only two of these are concerned with library services - the Massachusetts Commission for the Blind and the Regional Library for the Blind, located at Perkins Institute in Watertown. Many persons, other than the blind, require special library services, but, to date, little consideration has been given to their library needs. They are served in other ways by public and private agencies including hospitals, rehabilitative centers, schools, and other organizations devoted to the welfare of persons with a particular kind of handicap.

A list of the agencies working with the handicapped is given in the *Directory of Social Health, Welfare, and Rehabilitative Services of Massachusetts*, produced by the Massachusetts Rehabilitation Commission and United Community Services of Metropolitan Boston, and compiled and edited by the research department of the Unity Community Services. This directory is arranged alphabetically by city and town; the names and descriptions of federal, state, county, or local public and private agencies are listed alphabetically within each town's listing. National and state-wide agencies are located in the city of their headquarters office; for some agencies, branch offices are listed under local communities.

The index lists organizations according to type of service rendered. Twelve agencies serve the blind, and forty-five agencies serve handicapped persons other than the blind. We interviewed ten of these agencies to find out the number of handicapped people in Massachusetts of each type, and the special library services which they require. The two major sources of special library materials for the handicapped and the services they provide are discussed below.

a. Regional Library for the Blind

The Regional Library for the Blind is geared primarily to recreational reading. The materials now furnished to the handicapped through the regional library include braille books, talking books, tapes, and large print books.* The library receives notification from the Library of Congress that an individual has been certified to use the library. The regional library then mails to the individual a brochure explaining the use of the library, order forms, and two sample books. Further book requests are made and filled through the mails.

The Library of Congress provides talking books and books in braille and on tape but not operating costs. The state pays \$10 for each handicapped person who uses the regional library at least once in the year. This payment will be increased to \$16/user in 1968.

*All of Massachusetts' handicapped readers can use this service if they obtain the medical certification required by the Library of Congress.

To a certain extent, the Perkins School has also subsidized the Regional Library because of the use of joint facilities, but, as of next year, the Perkins School will have its own library, which may affect its subsidy program.

b. Department of Special Education

The Department of Special Education is in charge of the education of all blind students in Massachusetts, including students at Perkins as well as those in public schools. The Department of Education is responsible for supplying the book needs of the students in public schools. Braille, tape, or large print books to match those being used in the regular school classes must be supplied. Table 13 shows the number of books on hand at the Department of Special Education.

TABLE 13

ESTIMATED INVENTORY OF BRAILLE AND LARGE-PRINT VOLUMES

Braille Volumes

For storage (copyright dates before 1950)	1,508	
Active	9,560	
Subtotal		11,068

Large-Print Volumes

For storage (copyright dates before 1950)	1,615	
Active	9,688	
Subtotal		11,303
Total		22,371

The Department of Education pays for the books in the following way: (1) The federal quota to state agencies and schools provides \$50 for each legally blind child for text-books and talking books, tapes and equipment bought from the American Printing House for the Blind; thus, the state receives about \$15,000 for the approximately 300 legally blind children; (2) about \$10,000 of state funds is made available for purchases of books from out-of-state or for taping and brailleing of books by volunteers; and (3) the state appropriates \$2,000 for large-print books. In addition, the state pays for salaries and overhead.

2. Users of Special Library Services

a. Estimate of Number by Type

It is difficult to estimate the number of handicapped persons in Massachusetts who require and would be interested in using special library services. It is even difficult to determine how many individuals suffer from various types of handicaps. For example, organizations, such as the Muscular Dystrophy Association, which provide substantial services at no cost to the patient, feel that they may be in contact with only one-half of the handicapped of that type. Nonetheless, it is possible to make some estimates of the numbers of persons in each of five groups which are significant potential users of special library services; Table 14 presents these estimates.

Table 14

ESTIMATED NUMBER OF HANDICAPPED IN MASSACHUSETTS BY TYPE

	Blind	Visually Handicapped	Muscular Dystrophy	Multiple Sclerosis	Paraplegics	Cerebral Palsy
Massachusetts Total	9,300	16,000	1,200	7,000	12,000 - 17,000	8,000
Covered by Organization Interviewed	9,300	N.A.	600	1,000	350	400
Percent Covered	100	N.A.	50	14	2	5

Sources: Massachusetts Commission for the Blind, Library of Congress estimates (visually handicapped), Muscular Dystrophy Association of America, Massachusetts Chapter, Massachusetts Multiple Sclerosis Society, Association of Paraplegics, and United Cerebral Palsy Association of Massachusetts.

The most comprehensive data available for these estimates was on the blind because blindness is the only disability which must be registered with state authorities. The Massachusetts Commission for the Blind is required by law to maintain a register of all blind persons in the state. Likewise, all superintendents of institutions, hospitals, clinics, and all physicians and optometrists who, after examination, find a person legally blind are required by law to report this fact to the commission within 30 days. However, for various personal reasons, many legally blind persons still do not register their disability.

Although we do not have a complete enumeration of all handicapped individuals in the state, it is useful for library planning purposes to know the number of disabled persons affiliated with the relevant organizations. Three types of people do not belong to a relevant organization although they are handicapped:

- (1) Those who wish to identify themselves with the nonhandicapped rather than the handicapped;
- (2) Those who are so severely disabled they have lost all interest in social contact; and
- (3) Those who are not aware of the existence of the organization.

Experience shows that not all individuals eligible for special library facilities will use them. For example, out of a total 9,300 blind persons in Massachusetts, only about 2,500 use the Regional Library for the Blind. If the experience with the blind extends to physically handicapped persons, about one quarter of the total may, in fact, use library services established for them.

b. Age Distribution by Type

(1) Blind. Because of the necessity of certification for the blind, the age and sex distribution are well documented. The Massachusetts Commission for the Blind reported the distribution given in Table 15.

TABLE 15

BLIND PERSONS ON THE MASSACHUSETTS REGISTER OF THE BLIND
BY AGE AND SEX, DECEMBER 31, 1964

Age (years)	Male	Female	Total	Percent of Total
Under 5	40	33	73	0.8
5 to 19	461	410	871	9.2
20 to 44	778	589	1367	14.4
45 to 64	1102	1011	2113	22.4
65 to 74	747	1007	1754	18.5
75 to 84	710	1120	1830	19.4
85 and over	366	749	1115	11.8
Age Unknown	116	214	330	3.5
Total	4320	5133	9453	100.0

Source: Division of the Blind, Commonwealth of Massachusetts,
Annual Report 1965, p. 20

As the table indicates, about 50% of the blind persons are over 65. Slightly more than 50% of all blind persons are females, because women outnumber men in the over 65 age group in the population at large. Among blind persons under 65, men outnumber women 2383 to 2043.

(2) **Visually Handicapped.** We believe that the age and sex distribution of the severely visually handicapped approximates that of the legally blind. Possibly, an even higher proportion of those over 65 are visually handicapped.

(3) **Muscular Dystrophy.** Muscular Dystrophy is a chronic disease of the muscles, characterized by a gradual weakening of voluntary muscular control. Muscular dystrophy progressively weakens the muscles, and, after a period of years, the patient is confined to a wheelchair and eventually to a bed.

About 66% of the known muscular dystrophy victims in the United States are children between the ages of 3 and 13. The same age distribution most likely applies in Massachusetts. There are four main types of muscular dystrophy which have various implications for use of library service:

- (a) **Pseudohypertrophic type** - the most prevalent form, it commences in childhood between the ages of 3 and 10; its course is more rapid than that of any other type; it is hereditary in 35% of all cases; and it affects three times as many males as females;
- (b) **Juvenile type** - commences in childhood or adolescence; its progression is slower, and patients may reach middle age; it is hereditary, and it affects males and females equally;
- (c) **Facio-scapulo-humeral type** - commences in early adulthood and affects the facial muscles, shoulders, and upper arms; patients generally live a normal life span, and it affects both sexes equally; and
- (d) **Mixed types** - group of conditions which commence between the ages of 30 and 50; the course of the disease is rapid, often causing death in 5 to 10 years; it is not inherited, and it can strike anyone.

Patients with the pseudohypertrophic type are unlikely to outlive their teens. The juvenile, facio-scapulo-humeral, and mixed types would seriously affect the patient's ability to turn pages and, perhaps, to hold up his head to read. With these patients, page turners and talking books would be of value; the record player would have to be operated by someone other than the handicapped person.

(4) **Multiple Sclerosis.** Multiple sclerosis is a chronic, usually progressive, and crippling neurological disease. About 66% of multiple sclerosis victims first become aware of the disease between the ages of 20 and 40. Onset of the disease before age 18 or after 45 is known, but rare. The disease attacks both sexes equally.

(5) Cerebral Palsy. Persons with cerebral palsy suffer from some injury or damage to the brain which results in difficulty in control of movements. Cerebral palsy most often attacks young children. In some cases, the disease is caused by brain damage at birth; in others, by RH factor problems. Some cases arise from traumatic causes, such as automobile accidents, so there are some cerebral palsy patients distributed in all age groups. Since life expectancy is shortened by cerebral palsy, there are fewer patients at advanced ages.

(6) Paraplegics. The members of The Massachusetts Association of Paraplegics are probably not representative of all paraplegics in Massachusetts. The association's membership has a heavier concentration among the better educated. About 30% are between 17 and 29, 25% between 30 and 40, another 25% between 40 and 50, and about 20% over 50.

Undoubtedly, since this is primarily a lobbying and social group, the very young and very old are underrepresented. It would be unwise to assume that from a small sample of 350 disabled persons who have special interests in common, one can generalize to the 12 - 17,000 persons in wheelchairs and leg braces. It would be safe to say, however, that paraplegics are found over the entire age distribution, with heavier concentrations in later ages.

c. Effects of Handicaps on Library Use

It is even more difficult to estimate the number of handicapped persons who require various kinds of special library materials than it is to estimate the number of handicapped persons in each group. With progressive diseases like muscular dystrophy, the requirements of the patient become greater as time goes on. The needs of a patient with multiple sclerosis also vary enormously over time. During periods of remission of his disease, he may read regular books with ease, but following an attack, he may be almost totally blind and may, in addition, be incapable of even holding a book.

Table 16 presents some estimates of the numbers and kinds of library materials (talking books, tapes and special devices) required by various groups. The table indicates that of the approximately 25,000 blind or visually handicapped people in Massachusetts, only 600 to 700 are braille readers, primarily because only 10% of the legally blind are totally blind and only 50% of that group read braille. All totally blind children in the Massachusetts school system are taught braille, but much blindness begins in later years when it may be difficult to learn braille. As we prolong lives with better medical practice, blindness as a result of old age will become even more common. For this reason, the relative importance of braille books, even among the blind, will continue to decrease. Thus, the extension of library facilities to physically handicapped persons will virtually not affect the number of braille books required but will affect the number of talking books, page turners, etc. required.

TABLE 16

ESTIMATED NUMBER OF PERSONS REQUIRING VARIOUS TYPES OF SPECIAL LIBRARY FACILITIES

	Blind	Visually Handicapped	Muscular Dystrophy	Multiple Sclerosis	Paraplegics	Cerebral Palsy
Estimated Total in Massachusetts	9,300	16,000	1,200	7,000	12,000-17,000	8,000
Braille Readers	600 to 700 (of which 200 in Perkins, 65 in public schools)	?	None	None	None	None
Large-Print Readers	?	16,000	No	No	No	No
Talking Books and Tape Readers*	2,700	Many	Some	Some	Some	Many
Need Page Turners or Other Devices	No	No	Some	Some	Some	Many

*Includes braille and large-print readers.

Sources: Massachusetts Commission for the Blind, Library of Congress estimates (visually handicapped), Muscular Dystrophy Association of America, Massachusetts Chapter, Massachusetts Multiple Sclerosis Society, Association of Paraplegics, and United Cerebral Palsy Association of Massachusetts.

d. Future Legislation's Effect on Use of Library Service

Legislation recently enacted by Congress authorizes the Library of Congress to extend its present services to the blind to any handicapped person certified as unable to read normal printed material because of physical limitations. This legislation will greatly expand the demand for special library services. It is estimated that nationally, a total of 2 million persons are now eligible for this specialized service.* Included in this figure are 420,000 blind persons who are already eligible, 600,000 who are visually handicapped (the near blind), 4,700 persons who have lost both arms, 8,000 persons who have lost all of their fingers, 1,600 persons who are in iron lungs or use other respiratory devices, and more than 750,000 persons who have cerebral palsy, multiple sclerosis, muscular dystrophy, Parkinson's disease, or other crippling ailments.

*Talking Book Topics, Vol. 33, No. 1 (January 1967) pp. 4 - 5.

Not all those eligible will take advantage of the expanded specialized library services. Judging from the rate of participation among blind persons, possibly only 25% of those eligible will avail themselves of the service. Only a vigorous merchandising effort will alter these figures. Participation rates in organizations concerned with the general care of the physically handicapped is low; one can expect that participation in library services will also be quite low. There are two reasons why participation in library services for the physically handicapped will not be complete:

- (1) Many handicapped persons have already evolved methods for dealing with this problem; they have developed their own ways to use public library facilities and read regular books;
- (2) It will be difficult to inform all those who are eligible for the special library service of its availability.

To accommodate additional readers, extra money has been appropriated to the Library of Congress to supply new titles and more copies of each title and to add personnel to specialized libraries now dealing with the blind. The Library of Congress anticipates that initially service will be provided largely by means of talking books; there should be very little additional demand for braille books. Not provided by the Library of Congress at this point are materials in large print, projected books and their projectors, page turners, and musical recordings. However, the Library Services and Construction Act funds can be used by public libraries and state agencies to acquire these and other resources which can be useful in carrying on an adequate program of library service to physically handicapped persons.

In the past regional libraries serving the blind have used a special franking privilege in sending out books to the blind through the mails. At this point it is not clear that this franking privilege will be made available to supply books for the physically handicapped.

Again, it will be very difficult to estimate the exact numbers of physically handicapped persons who will be demanding books from the regional library. However, we can make some kind of an estimate by estimating what percentage of each handicapped group have severe enough disorders to require special library services and then adjusting this figure by the participation rate for the blind.

(1) **Muscular Dystrophy.** About half of the patients with muscular dystrophy cannot hold a book sufficiently well to read regular books. Thus, about 600 persons in Massachusetts would require special library services; if one fourth of these do, in fact, demand them, there would be 125 users.

(2) **Multiple Sclerosis.** There are 7,000 persons in Massachusetts with multiple sclerosis; most will require special library services only in the latter stages of their disease, so the total audience may be only 1,000 persons. If one quarter of these desire special library services, there would be about 250 users.

(3) Cerebral Palsy. There are 8,000 persons in Massachusetts with cerebral palsy; most are quite severely afflicted, and perhaps half (4000) would require special library service. If one quarter of this number did, in fact, avail themselves of library services, there would be about 1,000 users.

(4) Paraplegics. There are 12,000 to 17,000 paraplegics in Massachusetts. Most of them could use local public libraries if they were made more accessible through the elimination of architectural barriers; this ideal solution will not be forthcoming in the near future, however. Assuming 15,000 paraplegics can use wheelchairs, possibly 10% (1500) will themselves have access in the next few years to barrierless public libraries. Many others, possibly half of the remaining group (7000) will have friends or relatives obtain material from public libraries. We may assume that one quarter of the remaining 1750 paraplegics will use special library services. They will request books and serials to be delivered to them. The kinds of material will not be special, but the mode of transmitting the material to the paraplegics will be. It appears best to have the supplying agency, concentrating on special materials, borrow the books and serials on ILL and send them by mail to the paraplegic clients.

Some paraplegics have lost both arms or all of their fingers and, therefore, will require additional special library services. The Library of Congress estimates there are about 12,700 such individuals in the United States.* Since Massachusetts residents make up 2.7% of the U.S. population, it is reasonable to assume that about 2.7%, or 340, of the 12,700 individuals without fingers or arms live in Massachusetts. If about one quarter request library services, there would be about 85 people requiring the additional special services.

(5) Visually Handicapped. Many visually handicapped persons are eligible for special library services. The Library of Congress estimates that there are 600,000 persons who are near-blind and unable to read regular print. Since Massachusetts residents make up 2.7% of the U.S. population, we can expect that 2.7%, or 16,000, of the visually handicapped live in Massachusetts.

Many of the near blind have failing eyesight because of advancing age. Among this group it might be reasonable to expect a lower participation rate in library services. Furthermore, since the visually handicapped are not affiliated with an organization, it will be difficult to inform them of their eligibility for the service. If one eighth of the near blind apply for special library service, there will be about 2,000 users. The requirements of this group could be met partly by large print books distributed through local libraries.

(6) Total Users. From the five groups of physically handicapped, we can expect an increase in demand by 5,225 persons, distributed as follows:

Muscular Dystrophy	125
Multiple Sclerosis	250
Cerebral Palsy	1,000
Paraplegics	1,850
Visually Handicapped	2,000
	<hr/>
	5,225

**Talking Book Topics*, Vol. 33, No. 1 (January 1967) pp. 4 - 5.

An increase of 3,225 readers would be due to extension of service to the physically handicapped, and an increase of 2,000 readers to the extension of service to the visually handicapped. Since there are about 2,700 Massachusetts readers at the Regional Library for the Blind, an increase in the demand for special library services of this size would represent almost a 200% increase in total demand. Not all new readers will become involved in the program immediately, but participation should be about 50% the first year, for an increase of more than 100% in readership for the regional library.

One of the greatest needs of the handicapped is for service – the actual door-to-door delivery and return of library items. No matter how elaborate the program to build up collections, increase staff, provide consultant service from the state level, this helplessness on the part of a very large number of handicapped people will always keep them from enjoying the services which seem to be available but, in fact, are not. The state consultants and the public library systems should promote this program vigorously. If they do, we believe that the use figures referred to will be minimum rather than maximum levels.

3. Materials and Resources

Certain types of library materials have been developed to serve the requirements of the handicapped persons; these materials are discussed below.

a. Braille Books

Although only 5% of the blind in Massachusetts can read braille, many of these people are young students who require many books. The Department of Special Education estimates that each public school child requires an average of 10 to 15 books per year just for course work.

Braille books are quite expensive to produce since one page of printed text requires about three braille pages. For example, in braille *Lord Jim* is 4 volumes and costs \$11.40 from The American Printing House for the Blind. *Gone With The Wind*, a long book, fills 13 volumes and costs \$41. Some books are not readily available in braille and must be specially "brailled." In Massachusetts, the needs of students and professional persons are taken care of by the National Braille Press (NBP), a nonprofit organization employing volunteers for this service. Women's groups doing braille charge 5¢/braille page. Since about one page of regular text converts to three pages of braille text, preparation of a 200-printed-page book costs about \$30; copying costs about 5¢/page. The volunteers usually provide the paper, and braille typewriters (Perkins writer) or guide and stylus are provided by NBP.

b. Talking Books

Talking books, like braille books, are made to order for the Library of Congress by such groups as American Foundation for the Blind, New York, and American Printing House for the Blind, Louisville, Kentucky. Talking books are discs, like records, but are

recorded at much slower speeds (24, 16, or 8 rpm) in order to get more on a single record. Talking books are sent through the mails in cases similar to those for movies. The one disadvantage of talking books is that they tend to get scratchy after about 24 readings.

Talking book machines (specially designed record players capable of accommodating long-playing records at speeds of 33-1/3, 16-2/3, and 8 rpm) are provided by the Library of Congress and distributed free of charge to all legally blind applicants through a special section of the Commission for the Blind. The commission awaits notice of certification from the Library of Congress before delivering a talking book machine. The commission then notifies the regional library that there is a new subscriber. In the past 12 years, the circulation of talking books at the regional library (covering Massachusetts and other New England users) has more than doubled, increasing from 49,100 in 1954 to 131,000 in 1965.

c. Tapes

Tapes may be a very suitable substitute for talking books because tapes do not wear as easily as talking books. The tape section at the regional library was started in January 1966. Tapes cost \$5 to \$10/book and can be ordered through the same sources as talking books, as well as from Recording for the Blind, New York City. Again, when the titles desired are not already available, they can be made up by volunteer groups. This service is performed by NBP, which gives first preference to students and second preference to professional people. Since the readers for the tapes are volunteers, there is no labor cost. The tapes are 18,000-foot, 2-track tapes, which are bought wholesale for about \$1.75. Even though one book may require several reels (an average of five), tapes are still less expensive than braille. They are also much easier than braille to send through the mail.

Tapes have the advantages of being easy to copy and of retaining their clarity almost indefinitely, but they also have some disadvantages. Tape recording machines cost more than talking book machines do. At present, books on tape can be ordered only by those who have their own recording machines. Another disadvantage of using tapes on regular recorders is the danger of recording over or erasing what is already on the tape. Tapes also have a tendency to break, and the physically handicapped or blind person may not be able to do the necessary splicing.

d. Large-Print Books

Large-print books are required by many persons with partial sight. The two basic ways of producing large-print books are: (1) enlarging an existing book or (2) printing an entirely new book. The Department of Special Education has had experience with both methods and has found the latter more satisfactory because the print is clearer and easier to read and the book itself is easier to handle since it need not be oversize.

The American Printing House has 363 titles in large print. This service is quite expensive, costing about \$60 per volume. Recently, NBP began to produce large-print books. Prison inmates at Walpole State Prison have been typing large print on special typewriters. Their books cost about \$2.90/volume to produce, and an average book has 5 volumes.

e. Page Turners and Projection Devices

At present, this special equipment is not provided by the regional library. However, individuals who have acquired page turners indicated that the devices available are unsatisfactory since they are difficult to handle and difficult to adjust for books of various sizes.

B. FUTURE LIBRARY SERVICES TO THE HANDICAPPED

1. Certification

To receive federal funds for library service to the handicapped, it is necessary to have accurate up-to-date information on all users of specialized materials. We recommend that physicians, public health officials, welfare workers, and local public librarians be authorized to certify potential users, under guidelines established by the Bureau of Library Extension. An effort should be made to make the registration procedure as simple as possible, since only the most avid readers will avail themselves of services if the initial process is too complex. Simple registration procedures also will encourage participation by those members of the community, particularly older persons with visual handicaps, who might feel that a social onus was attached to such certification.

Hospitals, especially those with terminal patients, should be given "blanket" certification, which would allow them to distribute special materials to patients at the discretion of the hospital staff. Since many persons who eventually will be eligible for special services spend some time in hospitals, this would be an excellent opportunity to acquaint them with the facilities which are available to them. Certain other patients may develop temporary disabilities with their hands or eyes. In these cases, the patients might welcome the opportunity to use talking books, page turners, etc., yet would not be qualified for continued certification as a handicapped person. During the period of disability, the hospital could supply their library needs.

Certification for the use of all special materials may not be wise in some cases, particularly for children with visual handicaps. It may be beneficial to allow them to use large-print books, but not tapes or talking books, since there is an educational advantage in learning to read. Individual judgment, following the Bureau of Library Extension standards, will have to be used in situations of this sort.

2. Location of Materials

The main objectives of providing special library services to the handicapped are basically the same as those which motivate library activities in general; to supply the informational and recreational reading needs of the public served. However, in offering service to the handicapped, secondary objectives must be considered. One of these is the aim of integrating the handicapped with the rest of society as much as possible. To a certain extent,

the Department of Special Education seeks this integration when it encourages handicapped children to go to regular public schools rather than to special schools where they will be isolated and will not learn how to participate in the regular activities of the community.

The concept of integration raises a basic question concerning the location of library services to the handicapped. Should library services be provided as they are now, from a regional library which operates by sending books and receiving requests for books through the mail, or should services be provided through the local public library? At the present time, the Regional Library for the Blind seems to be doing an adequate job in the area of braille material. This service could be improved through changes in the cataloging and circulation systems. Space and staff limitations, however, indicate that Perkins may not be able to cope with the expected increases in acquisition and demand for materials when all segments of the handicapped population become eligible for special services.

Because of this consideration, and the desire to integrate library service to the handicapped with all aspects of library service, we recommend that all special materials, other than braille, be located at the three regional resource centers in the state, which now serve public libraries but will eventually serve all types of libraries. Local public libraries may wish to purchase selected large-print books, talking books, and tapes. Such purchases would be made at their own discretion, though it is hoped that they would make their holdings known and available to all potential users in the state, through inter-library loan.

3. Catalogs

The Bureau of Library Extension should maintain a catalog of all library resources for the handicapped which are held in the state. In addition, it should be apprised of holdings available elsewhere in the nation. This catalog should be reproduced and distributed to all local librarians because they are probably the best point of contact for the individual user. The local librarian can familiarize himself with the needs and interests of the user and can give assistance in the selection of material.

At the present time, there is very little interaction between the user and the Regional Library for the Blind. A list of available books is mailed to the user, who then checks off 25 titles which he is interested in reading. This list is put on file at the regional library and as one of the books becomes available, it is mailed to the user. The user may also telephone the regional library and request a specific book. However, if the book is not available at the moment, it is not reserved and alternatives are not suggested.

The several disadvantages to this system are:

- (1) The catalog list is printed; it is not on tape; therefore, the handicapped user must have the assistance of another person in reading the list and marking selections;

- (b) The selection of books from the check list of 25 is rather haphazard; it is difficult for the user to concentrate on a particular subject, since he may receive a book on political history one time and art the next;
- (c) One book must be returned before a second will be sent out; thus, cross-reference by the user is prevented and subject concentration is further impeded; and
- (d) If a user has need for a particular book within a given time period, he must make continual calls to the regional library in the hope that the book will finally be available when he calls.

By making the total catalog available on tape and at local libraries, better communication between the user and the library should be achieved. The local librarian will also be able to make alternate suggestions when a particular book is not available.

4. Circulation Control

Each handicapped person certified for use of special materials should be issued a numbered library card. In addition, each braille book, talking book, large-print book, and tape should be given a unique number. It is important that this number be given to each piece of material, rather than each title. When a book is charged out, it should be charged by card number, item number, date, and location. This information should be relayed to the coordinating center at the Bureau of Library Extension, and a duplicate set of information should be inserted in the book. When the book is returned, this information will again be sent to the Bureau to purge the file.

With this system, the location of all material can be determined quickly by a phone call or teletype message to the Bureau. If the desired title is not available, the user can be told when it will be returned, and he can plan his reading accordingly. A circulation system of this type also will give a record at the end of a year of what material was in use and who was using it. These records will be helpful when new material is being selected and also will provide the statistical records necessary for federal support. If the records indicated that certain potential distributors (e.g., terminal hospitals) were making little use of the special materials, an effort could be made to promote better utilization.

5. Consultants

The Bureau of Library Extension should provide consultant services for the promotion of library service to the handicapped. Services would include visits to distribution points, as well as individual instruction to the handicapped in the use of special equipment.

There should be a direct telephone line to the Bureau so that the handicapped could call the consultant (at no cost to themselves) and request information and assistance. The consultant should also be responsible for publicity about programs available to the handicapped. Such publicity might involve newspaper releases, displays at local libraries, radio announcements, etc. Every effort should be made to inform all potential users of the services to which they are entitled and the method of registration.

V. NEW ENGLAND LIBRARY COOPERATION

Although our work was concerned directly with library service within the Commonwealth of Massachusetts, it has become increasingly apparent to us that the possibilities of a more far-reaching network of libraries should be considered. The logical extension, in terms of geography and patterns of service, would be a library network encompassing all of New England. While the crossing of state boundaries will undoubtedly raise some problems, the advantages are too great to be ignored.

A. NEED

Population statistics indicate that as of 1960, the New England region contained 10.5 million persons. It is projected that by the year 2000, this figure will reach 16.2 million.* Population in general is already centered in urban areas, and in the ensuing decades, urban and suburban areas will continue to draw increased shares of the population (76% in 1960, 86% projected for 2020). Urbanization will facilitate the dissemination of library materials, but each state will still face the need to serve its rural populations through improved methods of communication.

While each state in the area has its own individual economic characteristics, certain factors distinguish the region as a whole. Economic growth, for instance, has traditionally been at a higher rate in New England than in the nation as a whole. More than other parts of the country, New England has a high emphasis on service industries as opposed to resource and manufacturing activities. These service industries include construction, finance, insurance, real estate, government (including education), and private services, all of which rely on libraries in one way or another as sources of information. This segment of the economy is expected to continue its expansion and will account for the highest percentage of the labor force in the decades to come.

These factors point toward the homogeneous character of the New England states in regard to economic scales. Transportation also links the states together through a good network of highways, bus service, and air transport. Even in the field of library service, small-scale efforts have begun; these include the New England Library Association, a forum for discussion of common problems and ideas, and, even more impressive, the New England Board of Higher Education, engaged in setting up a technical processing center for New England colleges, on a grant from the Council on Library Resources.

These activities, however, have only scratched the surface of the type of cooperation which could exist. Each state in the region contains certain large library resources. These include the collections of large universities, extensive state libraries, and certain special libraries. Through the use of interlibrary loan, some of these resources are being used, but in a somewhat haphazard fashion and to a relatively small extent.

*These and ensuing statistics were obtained from **Projective Economic Studies of New England**, a report by Arthur D. Little, Inc., to the U. S. Army Engineer Division, New England Corps of Engineers (1964-1965).

B. PRELIMINARY REGIONAL CENTER

The establishment of a New England Regional Library Center will be a substantial project and will require considerable planning. The most immediate need is to develop strong library networks within each state. A strong Massachusetts network is, of course, the major concern of this report. Improvement in state-wide library service will be the continuing goal of those concerned with library administration in Massachusetts. While these improvements are being made, however, there should be a concomitant effort to improve cooperation among the New England states. This cooperation should be deferred until all aspects of a sophisticated system can be worked out. We suggest that the representatives of the library agencies of each New England state get together as soon as possible to organize preliminary cooperative efforts. These measures should include consideration of:

- (1) Teletype connections between each state library center, which would be of great use when dealing with interlibrary loans which involve the resource libraries of each state;
- (2) Communication with the library network of New York State; many new programs are being instituted in New York to tie together the resources of all libraries in the state—public, academic, and special—as well as to maintain better interaction with other states. As New York programs develop, it would seem to be an excellent time for the New England states to be in close communication with their neighbor and share in the benefits of cooperation; and
- (3) Facsimile transmission units for each state library agency, which would permit the rapid transfer of printed material between the central library offices of each state and from them to local users and also would permit a tie-in with New York's FACTS system, which links together the major academic institutions of that state.

C. EXPANDED REGIONAL CENTER

Following this initial stage of basic cooperative activities, the regional organization should be expanded and/or reorganized into a formal entity. We suggest that it might deal with the following activities:

1. Information Retrieval

The regional center would serve as a computerized clearinghouse for interlibrary activities. It would coordinate ILL searches for the region and would maintain an appropriate balance between use of the major resource centers. Through statistical records, requests would be channeled to as many different libraries as possible, and the excessive ILL burden now placed on the largest libraries would be reduced.

Pilot projects could be introduced in the use of facsimile transmission and other types of rapid communication. The center would maintain communication with national library agencies, such as the Library of Congress, National Library of Medicine, and the Center for Research Libraries.

2. Studies of Library Use

The regional center could also function as a research center, performing studies on the subjective issues facing libraries today, such as why people do or do not use public libraries. The center could study methods of stimulating reader interest and new methods of bringing library materials to the public. These would be extensive projects which might be substantially funded by the Federal government, through such agencies as the Bureau of Research, which has a present appropriation of \$3.5 million for library research.

D. ORGANIZATION AND FUNDING

To function efficiently and provide the indicated services, the center should be operated as a distinct organization with full-time employees, rather than as a committee effort. A board of trustees should be instituted, composed of the participating state librarians and other leaders in the library field in New England. The director of the regional center would be accountable to the board.

Funding could proceed on several bases. Participating libraries might be charged fees according to size of their library and/or their use of the center. There might be state appropriation based on population, which would be part of the states' contribution to public library service. The latter would be more effective, since it would encourage all libraries to participate in a service which was automatically made available to them.

Many legal questions would occur, of course, in the establishment of such a center. We feel that the representatives of the participating state library networks should appoint a planning committee. This committee should include lawyers who would be able to work out the necessary details relative to a board of trustees and the accompanying legal responsibility, organizational structure, and funding. Action on this project should begin as soon as possible.